



Relion[®] protection and control

For generation, transmission and sub-transmission applications

Content

Protection and Control has a name - Relion®	4
Relion® protection and control	5
Our offering for generation, transmission and sub-transmission applications	5
Line distance protection	6
REL670/650	6
Line differential protection	10
RED670	10
Transformer protection	14
RET670/650	14
Busbar protection	18
REB670	18
High impedance differential busbar protection	22
REB650	22
Distributed busbar protection	24
REB500	24
Bay control	28
REC670/650	28
Breaker protection	32
REQ650	32
Generator protection	34
REG670/650	34
Wide area protection	40
RES670	40

Relion® 670 series – maximum flexibility and performance	42
Relion® 650 series – ease of use from ready-to-use solutions	43
COMBIFLEX® and COMBITEST	44
Proven and reliable solutions for protection and testing	44
Protection and control IED manager	48
PCM600	48
Integrated engineering tool	50
IET600	50
Integrated testing tool	52
ITT600 SA Explorer	52
Services	54
Excellence in real time power system simulation	56

NB!

This brochure contains generic descriptions of ABB protection and control products and solutions.
Please refer to release specific datasheets for details of available product configurations and functionality.

Protection and Control has a name Relion®

We have collected more than 100 years of engineering knowledge in products that will empower your business for many years to come. The state-of-the-art products have inherited their philosophy and algorithms from previous generations of proven ABB masterpieces. The past has been future-proofed through designs that embrace the core values of the IEC 61850 standard. You can be completely confident that your grid will stay profitable for many years to come.

To protect and control

ABB brings extensive experience in the field. You will benefit from personnel safety, reduced materials damage, and minimized system and grid down-time as a result of our experience wrapped up in the latest technology.

The best fit for your need

Whatever your need, the Relion family has a solution. You can pick a ready-to-use product for standard solutions or choose products that can be tailored to meet any application need with a multitude of configuration possibilities. It is your freedom of choice and we will support you with our engineering experience all the way.

Keep your cost of ownership at a minimum

The Relion family will not only protect your assets but it will provide an unrivalled cost-performance ratio through the multi-object protection and control. For instance, you can protect and control a power transformer and a transmission line with the same Relion product. Or, you can integrate main and back-up protection in the same product. This translates into higher reliability and lower cost of ownership in your grid and system.

We are always with you

Product training, grid analysis, application configuration, system engineering, network simulations, product certifications or just a chat about protection philosophy? Our global network of experts and application specialists is always close by, ready to assist you and make sure your business stay in top shape.

Power and productivity is our promise.

ABB Substation Automation Products in Västerås, Sweden



Relion® protection and control

Our offering for generation, transmission and sub-transmission applications



Relion® 670 series
Maximum flexibility and performance for generation and transmission applications



Relion® 650 series
Ease of use from ready-to-use solutions for generation and sub-transmission applications



Relion® REB500
Distributed busbar protection



COMBIFLEX® & COMBITEST
Proven and reliable solutions for protection and testing

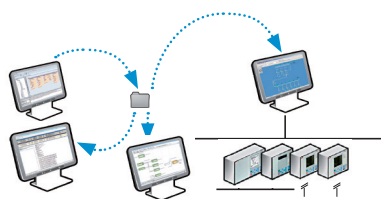

PCM600, IET600 & ITT600
Software tools



Services
Securing the full potential of your equipment

Line distance protection REL670/650

REL670 and REL650 line distance protection offer extensive protection application opportunities for overhead lines and cables, or combinations of overhead lines and cables. They feature full scheme distance protection with selective single-phase and three-phase tripping and autoreclosing with synchronizing and synchrocheck, power swing detection and a wide range of scheme communication logics. The IEDs with five zone distance protection for phase-to-phase and phase-to-earth faults enable you to protect transmission and sub-transmission lines and cables in impedance or solidly earthed networks. The IEDs are also equipped with residual overcurrent protection functions and a wide range of scheme communication logics that enable detection and fault clearance of high resistive earth faults.

REL670 – maximum flexibility and performance

The REL670 provide versatile protection, monitoring and control functionality with maximum flexibility and performance optimized for transmission and sub-transmission overhead lines and cables. The powerful IED provides distance protection for double circuit, parallel operating and series compensated lines. The fast distance protection with trip times as low as 13 ms allows for additional transfer capacity in the power lines. This, together with flexible and expandable hardware, allows the IED to meet your specific requirements. As a result, you can benefit from applications with multiple algorithms and comprehensive bay control functionality, including synchronizing, synchro-check, dead line detection and autoreclosing.

Furthermore, REL670 is able to protect and control several objects, for instance a combination of a line and a shunt



reactor with a single IED. As a result, this IED increases both the reliability and profitability of your entire power system.

The REL670 provide both customized and pre-configured protection solutions. The pre-configured IEDs are equipped with complete functionality adapted for four different configuration alternatives: single pole breaker or multi-breaker arrangements with single or three-phase tripping. If needed, they can be adapted to meet your power system's specific requirements. With the customized REL670 IEDs you have the freedom to completely adapt the functionality according to your needs.

REL650 – ease of use from ready-to-use solutions

REL650 offers optimum 'off-the-shelf', ready-made application solutions for protection and control of single breaker or multi-breaker connected power lines and cables. The type-tested variants are delivered equipped and configured with complete protection functionality, and with default parameters for easy handling of products – from ordering, engineering and commissioning to reliable operation.

The 650 series IEDs introduce a number of innovations, such as a significantly reduced number of parameter settings and extended IED HMI functionality including 15 dynamic three-color-indication LEDs per page, on up to three pages, and configurable push-button shortcuts for different actions. In the 650 series IEDs, most basic parameters are set before delivery from the factory. You only need to set the parameters specific to your application. The parameters related to line distance protection are mostly set as primary ohms, which significantly reduce the need to re-calculate the current and voltage values. This allows the IEDs to be quickly taken into operation. The application manual includes setting examples to support the protection engineer.

Extensive protection for lines and cables

REL670 and REL650 provide protection of power lines and cables with high sensitivity and low CT requirements. Measurements and setting of all five zones with several setting groups are realized completely independently to ensure high reliability. The distance protection function is available with both quadrilateral and mho impedance characteristics. This enables coordination with existing distance protection schemes in any power network.

The distance protection is further enhanced with load encroachment adaption, which increases the ability to detect high resistive faults on heavily loaded lines. This is especially

useful in sub-transmission networks where high line load needs to be allowed while high resistive faults need to be detected and cleared. The unique load current compensation in zone one prevents over-reaching during resistive faults and high power transfer on the line. Furthermore, an integrated power swing detection function prevents unwanted operation during power system oscillations caused by disconnection of parallel lines, heavy loads or tripping of large generators.

Versatile overcurrent functions provide additional back-up protection. The thermal overload protection will trip the line in overload situations to prevent more severe fault consequences.

Breaker failure protection allows high-speed back-up tripping of surrounding breakers and re-tripping of the own breaker, for instance to avoid operational mistakes during testing. This function is essential in substations that require local back-up protection. The distance, directional earth fault overcurrent and directional negative sequence overcurrent protection functions can communicate with the remote end in any communication scheme. The breaker monitoring function is capable of handling multiple breaker types in one IED. This means easier asset management and decreased need for non-regular maintenance of breakers.

The autoreclosing functionality increases operation security and is an effective way to restore the network after arcing faults. In REL670 and REL650, autoreclosing can be made using synchrocheck to eliminate the risk of unwanted reclosing during unfavorable circumstances.

In addition to the wide range of overcurrent protection functions, REL670 and REL650 provide a negative sequence overcurrent protection. This function detects all unsymmetrical faults with or without earth connection. It features high sensitivity, which enables detection of faults with a low fault current. The negative sequence overcurrent protection can also be used as directional. This facilitates the coordination with protection for other objects.

The multi-stage negative sequence overcurrent protection can serve as back-up protection for most faults. It can also serve as the main protection for earth faults and other unsymmetrical faults in radial lines.

REL670 can also provide additional logic in direct transfer trip schemes to minimize the risk of unwanted operation caused by a false signal in protection communication. Several

Line distance protection REL670/650



different protection functions can be used as local criteria when configuring the logic for a specific application.

Integrated protection and control

REL670 and REL650 are designed for IEC 61850, implementing all the aspects of this standard and thus ensuring open, future-proof and flexible system architectures, with state-of-the-art performance. Their performance meets comprehensive communication tasks, for example, GOOSE messaging for horizontal communication. These IEDs provide you with wide application flexibility, which makes them an excellent choice for both new and retrofit installations.

The advanced interlocking functionality allows you to avoid dangerous or damaging switchgear operations and to ensure personnel safety. The IED performs secure bay- and stationwide interlocking using an easy-to-use reservation functionality. This prevents simultaneous operation of disconnectors and earthing switches and ensures that the interlocking information is correct at the time of operation. The control is based on the select-before-operate principle to ensure secure operation and to avoid human mistakes.

The integrated HMI of REL670 and REL650 provide you with a quick overview of the status of the line and service values as well as instant access to important data, such as settings. Using a library of symbols, you can easily configure the graphical display to correspond to your needs and to your substation. The built-in disturbance and event recorders provide you with valuable data for post-fault analysis and corrective actions to increase the security of your power

system.

Furthermore, the HMI of REL670 allows secure and quick local control for stand-alone applications and provides back-up control for substation automation systems, when control functionality is integrated in the IED. The two-position versatile switch and the 32-position selector switch functions in REL670/650 enable you to easily manage switching operations via an icon on the IED HMI. The versatile switch function allows you to directly change, for instance, the autorecloser function from On to Off, or vice versa, without changing the configuration. The function also presents an indication of the selected position.

The selector switch can replace an external mechanical selector switch and allows you to directly select the position you desire, for instance, to change the autorecloser mode between 1-pole, 3-pole or 1- and 3-pole modes in REL670/650. In addition to the HMI, these switch functions can be operated from a remote system.

Fast and efficient system integration

The IEC 61850 compliant REL670/650 IEDs utilize ABB's unique connectivity package concept, which simplifies the system engineering and reduces the risks of errors in system integration. A connectivity package contains a complete description of the specific IED, consisting of data signals, parameters, addresses and IED documentation. The signal data is configured automatically based on the information provided by the connectivity package to efficiently integrate the IEDs in ABB's MicroSCADA Pro automation system.

Application examples

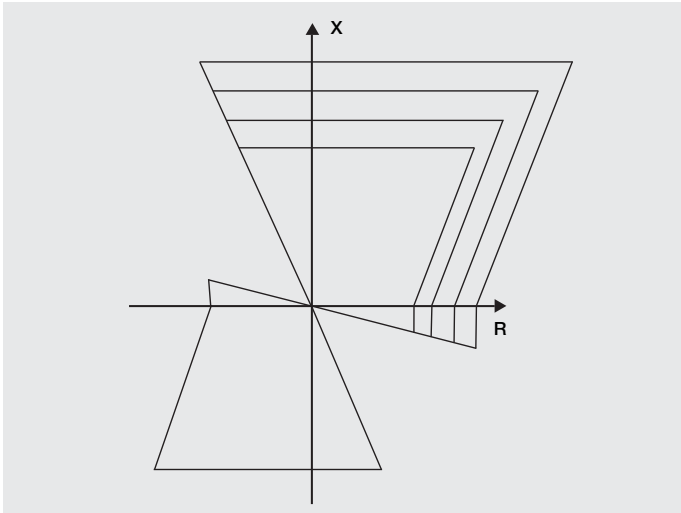

REL670/650 IEDs provide distance protection with quadrilateral characteristic.

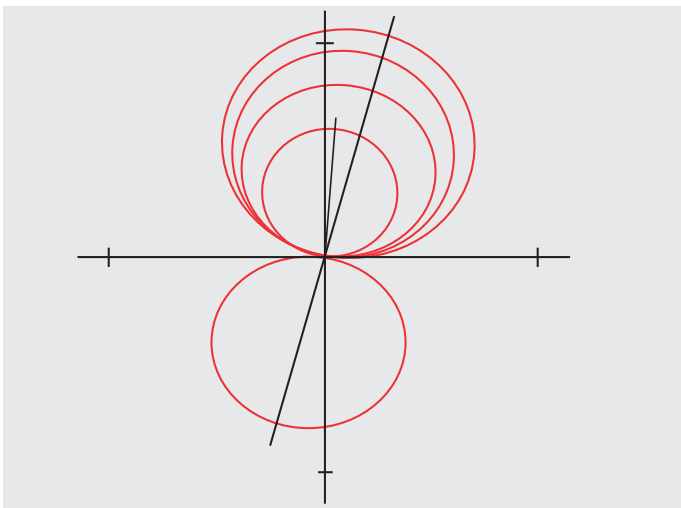

REL670/650 IEDs provide distance protection with mho characteristic.

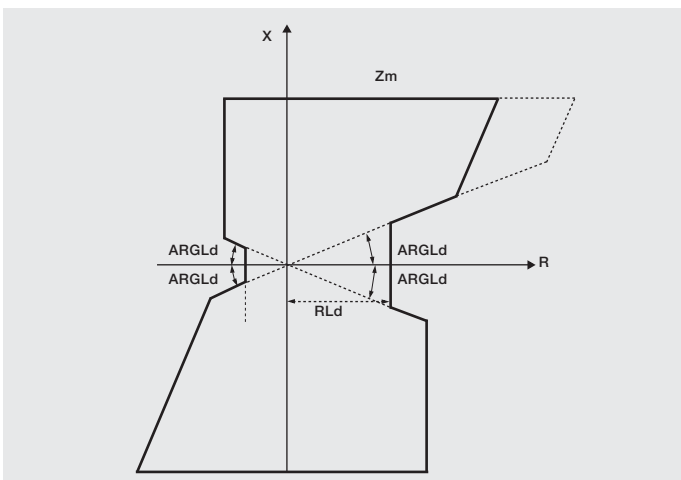

The load encroachment function allows the efficient detection of high resistive faults without interfering with the load impedance.

Commissioning and test is also easy and fast due to forcing of the binary outputs in the IED.

Relion® 670/650 series IEDs support IEC 62439 standard redundant communications on the station bus as per IEC 61850 standard. The solution from ABB utilizes the IEC 62439-3 standardized Parallel Redundancy Protocol (PRP). PRP improves the communication system reliability and features a unique capability of zero seconds' recovery time in case of communication failures. This means that there will be no interruption in communication if one link fails as the other link instantaneously takes over the communication. As a result, there is no data lost when communication failures have occurred.

The supervision of communication links provides real-time status information about both communication links individually. If a failure occurs, an alarm is sent to the IED HMI and the substation automation system. This also allows for maintenance of the station bus while it is in operation. Thus, redundant communication further improves personnel safety and ensures that the necessary information about the system is available for operators in all situations.

Relion 670 series IEDs can also support synchronized sampled measured value communication over the process bus using IEC 61850-9-2 LE which replaces conventional wiring between the process and the secondary system. This enables new design of substations. For example, utilization of sensor technology eliminates problems caused by, for instance, CT saturation and EMC influence. Furthermore, extensions and maintenance of substations can be completed more efficiently as fiber-optic cables are used instead of copper wires.

670 series IEDs allow you to mix conventional wiring and fiber-optic communication with IEC 61850-9-2 LE in a single IED. This way you can shift from conventional wiring for analog data to fiber-optic-based communication for synchronized sampled measured values step by step.

Line differential protection RED670

The RED670 is designed for protection, monitoring and control of overhead lines and cables with up to five line terminals. The phase segregated line differential protection of RED670 enables reliable single/two/three pole tripping and auto-reclosing with synchronizing and synchro-check. In addition, this IED can protect transformer feeders, generator and transformer blocks. It provides an extensive functionality with application opportunities and expandable hardware to meet your specific requirements.

RED670 provides selective protection without time grading. All line short circuits and earth faults can be cleared instantaneously. Additionally, the high sensitivity of RED670 allows for detection of small currents, which in turn allows high resistive phase to earth faults to be detected.

Ready to use IEDs

The RED670 is delivered pre-configured, type tested and with default parameters for easy handling of products – from ordering, engineering and commissioning to reliable operation. These IEDs are equipped with complete functionality adapted for four different configuration alternatives: single pole breaker or multi-breaker arrangements with single or three phase tripping. If needed, they can also be easily adapted for your power system's specific requirements.

Protection for up to five line terminals

RED670 provides phase segregated line differential protection for two to five line terminal applications in impedance or solidly earthed networks, including series compensated systems.

All individual phase currents in 1½ and multi-breaker configurations can be connected to RED670 without external summation. Therefore, each current will always be correctly measured. This improves the stability of the line differential protection function and enables integration of a number of breaker related protection and control functions.

Power transformer in the protected zone

RED670 is able to handle two or three-winding power transformer(s) in the protected zone. The line differential protection function handles all transformer winding vector groups and matches all transformer configurations with parameter settings. This simplifies engineering since no auxiliary CTs or other protection equipment is needed.

Advanced stabilization methods are used for detection of transformer inrush current during energization to ensure sensitive differential protection when a power transformer is



included in the protected zone.

When a small transformer is connected as a tap on the line, the line differential protection can be used without having an additional RED670 installed at the transformer tap. For low fault currents behind the tap transformer the line differential protection of RED670 includes a useful definite time or inverse time delayed characteristic. This enables selective operation of other protection functions located at the tapped transformer's high or low voltage side.

Extensive built-in protection for lines and cables

The RED670 features integrated distance protection to ensure fault clearance in case of communication failure. The full scheme distance protection provides independent phase selection, power swing detection and a wide range of scheme communication logics. The four-zone distance protection is further enhanced with load encroachment, which increases the ability to detect high resistive faults on heavily loaded lines.

You can increase the functionality of your RED670 IEDs with optional back-up and multipurpose protection functions. Versatile overcurrent and thermal overload functions provide additional back-up protection. Breaker failure protection allows high speed back-up tripping of surrounding breakers and re-tripping of the own breaker, for instance, to avoid operational mistakes during testing. The breaker monitoring function is capable of handling multiple breaker types in one IED. The distance directional earth fault overcurrent and directional negative sequence overcurrent functions can communicate with the remote end in any communication scheme.

In addition to the wide range of overcurrent protection functions, RED670 provides a four-step negative sequence overcurrent protection. The function detects all unsymmetrical faults with or without earth connection. It features high sensitivity, which enables detection of faults with low fault current. The negative sequence overcurrent protection can also be used as directional. This facilitates the coordination with protection for other objects. It can also serve as the main or back-up protection. Fast detection of fault location with accuracy of less than 1% means that faults in lines and cables can be repaired faster.

Integrated protection and control

RED670 is designed for IEC 61850, implementing all the aspects of this standard and thus ensuring open, future-proof and flexible system architectures, with state-of-the-



art performance. It features extensive functionality and expandable I/O. As a result, you can benefit from applications with multiple algorithms and comprehensive bay control functionality, such as synchronizing, synchro-check, dead-line detection and auto-reclosing in integrated and distributed architectures.

The advanced interlocking functionality of RED670 allows you to avoid dangerous or damaging switchgear operations, and thus ensure personnel safety. The control is based on the select before operate principle to assure secure operation and to avoid human mistakes.

The integrated HMI of RED670 allows secure and quick local control for stand-alone applications and provides back-up control for substation automation systems. It also enables instant access to important data, such as settings, events and disturbance information.

The two-position versatile switch and the 32-position selector switch functions enable you to easily manage switching operations via an icon on the IED HMI. The versatile switch function allows you to directly change, for instance, the autorecloser function from On to Off or vice versa without changing the configuration. The function also presents an indication of the selected position.

The selector switch can replace an external mechanical selector switch and allows you to directly select the position you desire, for instance, to change the auto-recloser mode between 1-pole, 3-pole or 1- & 3-pole modes. In addition to

Line differential protection RED670



the IED HMI, these switch functions can be operated from a remote system.

The RED670 provide you with a future-proof concept based on wide application flexibility, which makes these IEDs an excellent choice for both new and retrofit installations.

Protection communication according to the standards

Due to development in communication technologies and synchronization of measurements, line differential protection can be used in a wide range of applications. Consequently, you can also protect long lines using line differential protection and still maintain high security. RED670 can exchange phase current and binary signal information between up to five line terminals.

The RED670 is designed to communicate. They feature extensive supervision of communication channels and provide detailed information for fast restoration of the communication system. The built-in C37.94 interface of the RED670 enables easy and safe standardized optical connection to “off-the-shelf” communication equipment.

You can:

- Choose either master-master or master-slave operating mode depending on your system’s functionality or your economic requirements.
- Connect RED670 to redundant communication channels to increase the dependability of the protection scheme.
- Use GPS or IRIG-B module for time tagging of samples,

which allows RED670 to be used in switched networks with unequal channel delays.

- Use the echo-synchronization method for channels with stable and equal delays in both directions without time tagging of samples via GPS.

RED670 IEDs can also provide additional logic in the direct transfer trip schemes to minimize the risk of unwanted operation caused by a false signal in protection communication. Several different protection functions can be used as local criteria when configuring the logic for a specific application. Furthermore, the line differential protection function offers additional local criteria, such as phase-to-phase current variation. This ensures correct operation of the IED in case data is lost due to frequent failures in protection communication. Consequently, the protection system security is maintained, and the risk of interruption in electricity supply to customers is reduced.

Fast and efficient system integration

RED670 utilize ABB’s unique connectivity package concept which simplifies the system engineering and reduces the risks of errors in system integration. This package contains a complete description of the specific IED, consisting of data signals, parameters, addresses and IED documentation. The signal data is configured automatically based on the information provided by the connectivity package to efficiently integrate the IEDs in ABB’s MicroSCADA Pro automation system.

Integration, commissioning, and test is also made easy and fast due to forcing of the binary outputs in the IED.

Application examples

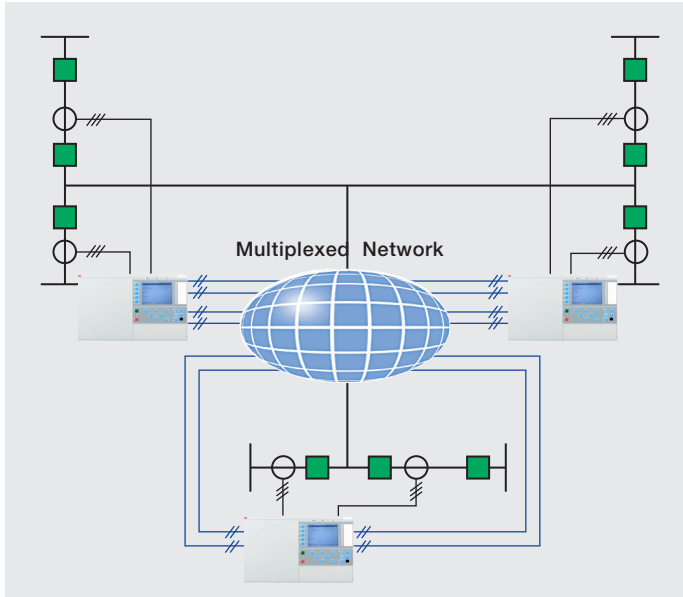

RED670 in three-terminal line application with individual phase current exchange.

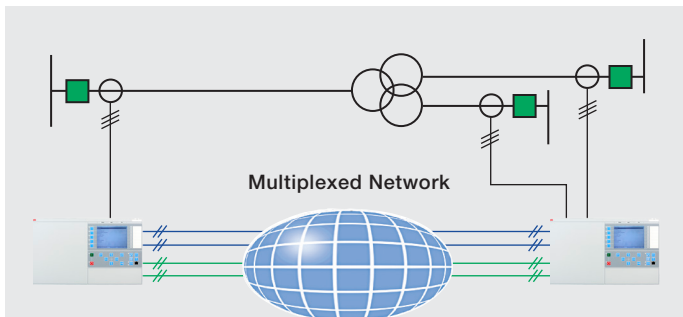

RED670 for line and three-winding transformer application with individual phase current exchange and redundant communication.

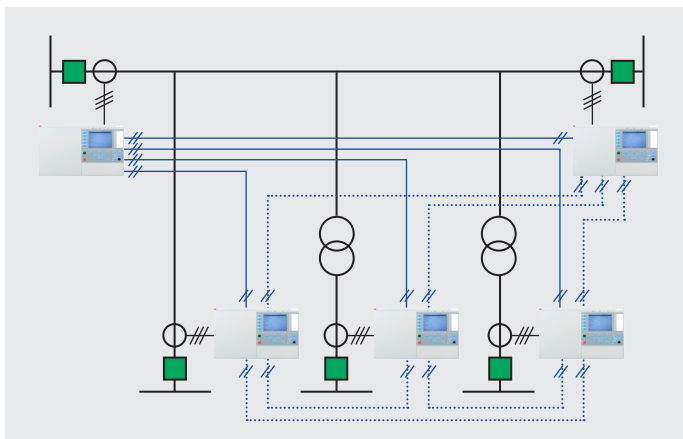

RED670 for five-terminal line application in master-master or master-slave operating mode.

Relion® 670 series IEDs support IEC 62439 standard redundant communications on the station bus. The solution from ABB utilizes the IEC 62439-3 standardized Parallel Redundancy Protocol (PRP). PRP improves the communication system reliability and features a unique capability of zero seconds' recovery time in case of communication failures. This means that there will be no interruption in communication if one link fails as the other link instantaneously takes over the communication. As a result, there is no data lost when communication failures have occurred.

The supervision of communication links provides real-time status information about both communication links individually. If a failure occurs, an alarm is sent to the IED HMI and the substation automation system. This also allows for maintenance of the station bus while it is in operation. Thus, redundant communication further improves personnel safety and ensures that the necessary information about the system is available for operators in all situations.

Relion® 670 series IEDs can also support synchronized sampled measured value communication over the process bus using IEC 61850-9-2 LE which replaces conventional wiring between the process and the secondary system. This enables new design of substations. For example, utilization of sensor technology eliminates problems caused by, for instance, CT saturation and lack of electromagnetic compatibility. Furthermore, extensions and maintenance of substations can be completed more efficiently as fiber-optic cables are used instead of copper wires.

670 series IEDs allow you to mix conventional wiring and fiber-optic communication with IEC 61850-9-2 LE in a single IED. This way you can shift from conventional wiring for analog data to fiber-optic-based communication for synchronized sampled measured values step by step.

Transformer protection

RET670/650

The RET670/650 provide fast and selective protection, monitoring and control for all types of transformers, such as two and three-winding transformers, step-up transformers in power stations and special railway transformers. In addition, RET670 offers state-of-the-art protection for autotransformers, phase shifting transformers and shunt reactors including apparatus control. With up to six three phase restraint current inputs into differential protection, it allows for multi-breaker substation arrangements on any transformer side. The advanced RET670 and RET650 communication capabilities allow you to integrate these IEDs into your substation automation system or use them as stand-alone multifunctional units.

The transformer protection IEDs offer several solutions for voltage control. Voltage control can be integrated in the same IED together with differential protection function and back-up protection functions, or as a separate stand-alone voltage control unit. The advanced voltage control functionality of RET670 is capable of handling single and up to eight parallel transformers in any combination of parallel groups. RET650 is capable of handling single and up to four parallel transformers.

These IEDs provide you with a future-proof concept based on application flexibility, which makes them an excellent choice for both new and retrofit installations. The integration of the main protection and a wide range of back-up protection

functions within these IEDs improve your power system performance. It also reduces engineering and installation time as well as space and spare parts requirements.

RET670 – maximum flexibility and performance

The RET670 provide customized or pre-configured protection solutions for any type of transformer and shunt reactor application. The customized RET670 gives you the freedom to select functionality entirely according to your needs. The pre-configured RET670 variants simplify handling since the basic functionality is included and pre-configured. If needed, you can add optional functions to increase the functionality of the pre-configured RET670 IEDs to meet the specific requirements of your transformer or shunt reactor.

Intelligent protection investment

You can also protect and control several objects with a single RET670 IED. For instance, a single RET670 IED can integrate complete protection and control functionality for a transformer and a connected transmission line. The distance protection function can also be used as back-up protection. The four-step negative sequence overcurrent protection can serve as back-up protection for most faults. It can also serve as the main protection for earth faults and other unsymmetrical faults on the outgoing lines.

Additionally, the advanced logic capabilities and multipurpose protection function of the RET670 allow you to design special applications. Together with MicroSCADA Pro automatic



operation of disconnectors and load transfer logics for a double busbar, and special control applications can be designed. The logic can be easily generated, tested and commissioned with the help of the graphical engineering tool.

Advanced voltage control

Tap changer control functions include line drop compensation and a load shedding function based on voltage reduction. RET670 tap changer position monitoring with mA- or BCD-signals enables supervision of the correct tap changer operation.

For parallel operating transformers, the RET670 and RET650 can utilize the minimum circulating current principle, which ensures the correct split of reactive power flow between each transformer in accordance with its rating. Using the average measured voltage between the IEDs within each group of transformers ensures the correct tap changer control. This also allows easy and efficient supervision of VTs. Alternatively the master-follower principle can be used for transformers with similar characteristics. Automatic control for a hot-stand-by transformer can also be included.

The RET670 IED can be equipped with integrated advanced voltage control functionality for single and up to eight parallel transformers in any combination of parallel groups.

RET650 provides integrated voltage control for single/parallel transformers. The dedicated voltage control variant of RET650

is capable of handling two parallel operating transformers including back-up protection.

The right information for the right action

The integrated HMI of RET670 and RET650 provide you with a quick overview of the status of the substation with position indications and service values. Using a library of symbols, you can easily configure the graphical display to correspond to your needs and to your substation. The built-in disturbance and event recorders provide you with valuable data for postfault analysis and corrective actions to increase the security of your power system.

RET670/650 features also functions for local and remote apparatus control on all sides of the transformer. Secure bay- and station-wide interlocking allows you to avoid dangerous or damaging switchgear operations and to ensure personnel safety. The large HMI allows for local control and instant access of important data, such as settings, events and disturbance information. You can locally control and visualize up to 30 primary apparatus with one RET670/650 IED.

The two-position versatile switch and 32-position selector switch functions of RET670/650 enable you to easily manage switching operations via an icon on the IED HMI. The versatile switch function allows you to directly change, for instance, a voltage control function from manual to automatic mode. The function also presents an indication of the selected position. The selector switch can replace an external mechanical



Transformer protection RET670/650



selector switch and allows you to directly select the position you desire. In addition these switch functions can also be operated from a remote control system.

The HMI features 15 dynamic three-color status indication LEDs on up to three pages, which is useful in maintenance and operation routines. It also has configurable push-button shortcuts that can be used for different actions. A virtual keyboard is available for easier password handling. Any local language with special characters can be used.

Optimized utilization of transformers

The monitoring functionality of the RET670 and RET650 provides important information about the state of the transformers to an operator. The RET670 receive information about the transformer temperature and issue an alarm, log the event and trip if needed. Early actions prevent forced ageing and prolong the transformer lifetime. The information about temperature can also be used to control the cooling system of the transformer.

Fast and efficient system integration

The RET670 and RET650 are designed for IEC 61850, implementing all aspects of this standard, thus ensuring open, future-proof and flexible system architectures, with state-of-the art performance. They utilize ABB's unique connectivity package concept, which simplifies the system engineering and reduces the risks of errors in system integration. A connectivity package contains a complete description of the specific IED, consisting of data signals, parameters, addresses and IED documentation. The signal data is configured automatically based on the information provided by the connectivity package to efficiently integrate the IEDs into ABB's MicroSCADA Pro automation system.

Relion® 670/650 series IEDs support IEC 62439 standard redundant communications on the station bus as per IEC 61850 standard. The solution from ABB utilizes the IEC 62439-3 standardized Parallel Redundancy Protocol (PRP). PRP improves the communication system reliability and features a unique capability of zero seconds' recovery time in case of communication failures. This means that there will

be no interruption in communication if one link fails as the other link instantaneously takes over the communication. As a result, there is no data lost when communication failures have occurred.

The supervision of communication links provides real-time status information about both communication links individually. If a failure occurs, an alarm is sent to the substation automation system. This also allows for maintenance of the station bus while it is in operation. Thus, redundant communication further improves personnel safety and ensures that the necessary information about the system is available for operators in all situations.

Relion® 670 series IEDs can also support synchronized sampled measured value communication over the process bus using IEC 61850-9-2 LE which replaces conventional wiring between the process and the secondary system. This reduces problems caused by, for instance, CT saturation and lack of electromagnetic compatibility.

670 series IEDs allow you to mix conventional wiring and fiber-optic communication with IEC 61850-9-2 LE. This way you can shift from conventional wiring for analog data to fiber-optic-based communication step by step.

Application examples

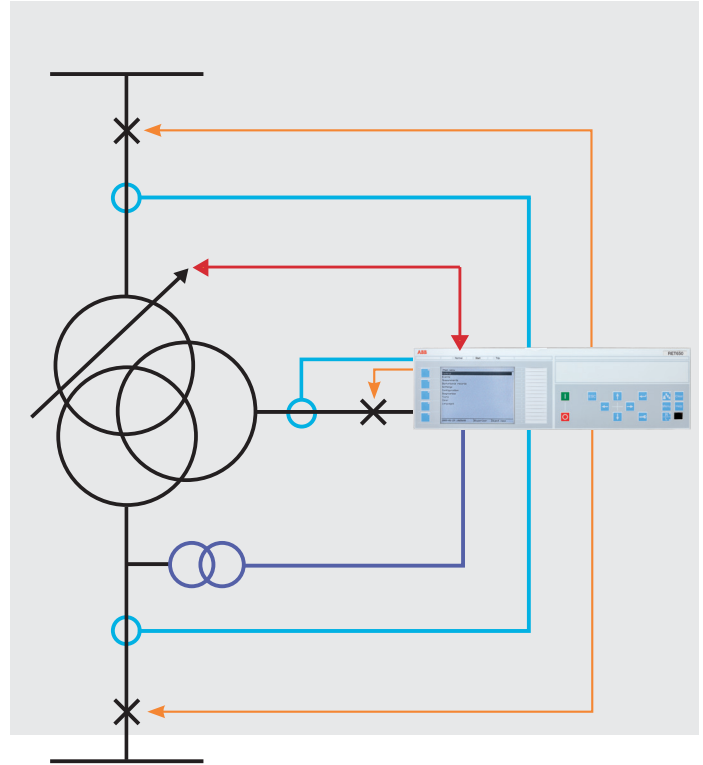

RET650 provides complete protection and control for two- and three-winding power transformers.

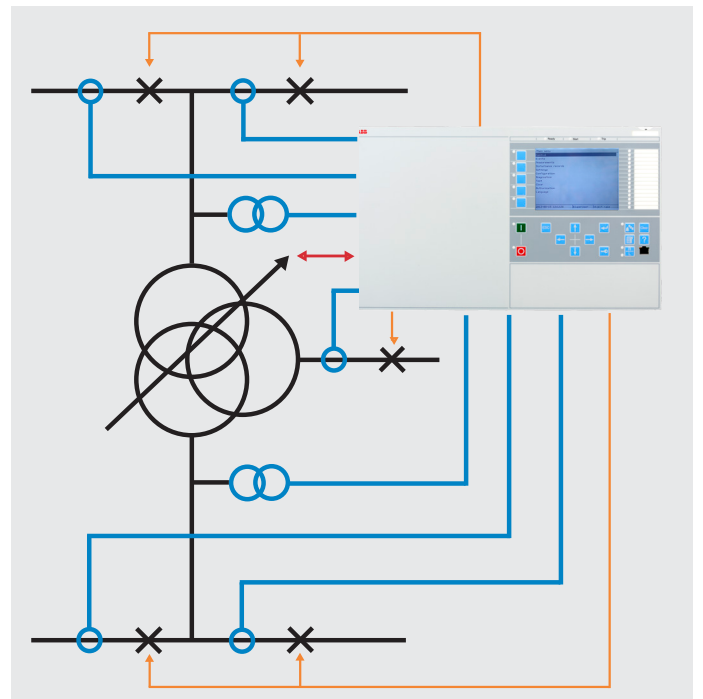

RET670 ensures enhanced through-fault stability for multibreaker arrangements

Busbar protection

REB670

The REB670 features excellent application flexibility. It is designed for the protection and monitoring of busbars, T-connections and meshed corners from medium to extra high voltage levels. Due to its extensive I/O capability, REB670 protects single and double busbars with or without transfer bus, double circuit breaker or one-and-half circuit breaker arrangements.

The REB670 IED provides selective, reliable and fast fault clearance for all types of internal phase-to-phase and phase-to-earth faults in solidly earthed or low impedance earthed power systems. It can also handle all internal multi-phase faults in isolated or high-impedance earthed power systems.

REB670 features complete busbar protection, which in addition to differential protection includes flexible dynamic zone selection (disconnecter replica) integrated in one IED. This enables dynamic CT connections to differential zones,

selective busbar and breaker failure tripping as well as disconnecter and circuit breaker status supervision. Due to its unique measuring principle, this IED has very low CT requirements compared to other numerical differential protection devices.

In-depth busbar protection knowledge

The REB670 continues ABB's strong track record in busbar protection, starting from analog busbar protection relays INX2/5, RADSS, REB 101/103. So far, these relays have been successfully installed for over 40 years. ABB also has more than 10 years of experience of numerical busbar protection based on REB500 and RED521. All these devices have shown an impressive track record with no false operation due to incorrect IED functioning. Today, more than 20 000 zones equipped with ABB busbar protection are in service throughout the world.



Always correct behavior

REB670 is fast and stable simultaneously – such a unique combination is essential for effective busbar protection. This IED features extremely short operate time, typically 12 ms, for most internal faults, regardless of the number of connected feeders. At the same time, it maintains complete stability for external faults, even when heavy CT saturation occurs. It also has very low CT requirements compared to other numerical differential protection devices due to its unique measuring principle, which allows the sharing of CT circuits with other protection relays and thus saves costs. The low CT requirements guarantee stability and correct operation as long as the CT is not saturated for at least two milliseconds during each power system cycle. Furthermore, the REB670 provides superior sensitivity to internal faults, thus protecting your power system objects from extensive damage and long repair times. Additionally, it effectively recognizes and operates correctly for all types of evolving faults.

Optimized performance

The REB670 features multiple algorithms in a single device. It features two differential protection algorithms: one basic and one with a sensitive operational level. The latter is able to detect internal busbar earth faults in low impedance earthed power systems, where a neutral point reactor or resistor limits the earth-fault current typically from 300A to 2000A. In addition, you can utilize the sensitive operation level when energizing the bus via long line, since this requires high sensitivity from busbar differential protection.

The innovative and fast measuring algorithm detects and prevents incorrect operation during open CT circuits. The supervision of open CTs of the IED allows you to design reset logic for the automatic re-start of the IED when the CT is re-connected. This supervision functionality can also generate alarms and trigger the disturbance recorder.

The integrated overall check zone feature can be used in double busbar stations to secure stability of the busbar differential protection in cases where status indication of a busbar disconnecter is entirely wrong in any of the feeder bays.

REB670 integrates zone selection functionality into a single IED and therefore no external equipment for CT switching and busbar protection trip routing is needed. The flexible zone selection allows automatic linking of CTs to the actual differential protection zone at any time.

REB670 provides maximum safety for your substation personnel in a fault situation. It also allows you to easily take a bay out of service for maintenance, and yet keep the busbar protection in operation during the maintenance period. You can disconnect the bay via the IED HMI or a selector switch. To sum up, REB670 is the most reliable solution for protecting the most precious assets of your power system: the most essential objects and your people.

REB670 is designed for IEC 61850, implementing all the aspects of this standard and thus ensuring open, future-proof and flexible system architectures, with state-of-the-art performance.

Easy to handle

The REB670 can be delivered pre-configured, type tested and with default parameters for easy handling of products from ordering, engineering and commissioning to reliable operation. These IEDs are equipped with complete functionality adapted for three different configuration alternatives in three- and one-phase variants. They can be applied for differential protection of busbar sections from four up to 24 CT inputs. All variants have two low-impedance differential protection zones and check-zone. You can use the graphical configuration tool Protection and control IED manager PCM600 to easily and intuitively adapt the pre-configured REB670 IEDs to your specific busbar arrangement. The integrated large HMI provides a quick overview of the magnitude and phase angle of all individual bay currents. It also presents the magnitude of differential and total through-load currents, bay CT connections towards two differential zones and check-zone. You can also access information about the actual status of primary switchgear objects, as well as trip signals and open CT indications. All this facilitates fast and efficient commissioning and consequently correct behavior of the busbar protection.

The two-position versatile switch and the 32-position selector switch functions enable you to easily manage switching operations via an icon on the IED HMI. The versatile switch function allows you to directly enable, for instance, the bay out of service feature or to directly disable a whole differential zone. The switch function also presents an indication of the selected position.

The selector switch can replace an external mechanical selector switch and allows you to directly select the position you desire. In addition to the IED HMI, these switch functions can be operated from a remote system.

Busbar protection REB670

Cost-efficient extensions

You can easily integrate extension bays into your existing REB670 IED. The station extensions can be done bay-by-bay without any software or hardware modifications within the protection IED. For instance, if you have a nine-bay station you can, by ordering a 12-bay variant, have everything included and prepared for all 12 bays. Thus, when extending your substation, all you need to do is to connect the wiring for the new bays and enable relevant functionality in the REB670 IED.

Save space and money

REB670 provides complementary integrated functionality in a single device. The integrated breaker failure protection for all breakers in any type of station layout allows easy implementation of complete back-up protection.



Application examples

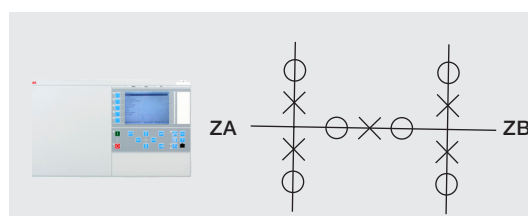

H-type station.

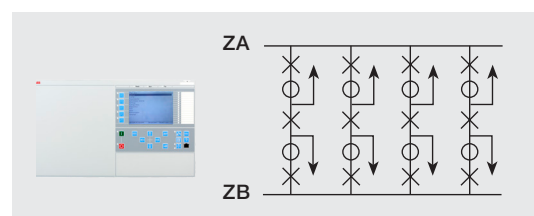

1 1/2 breaker stations.

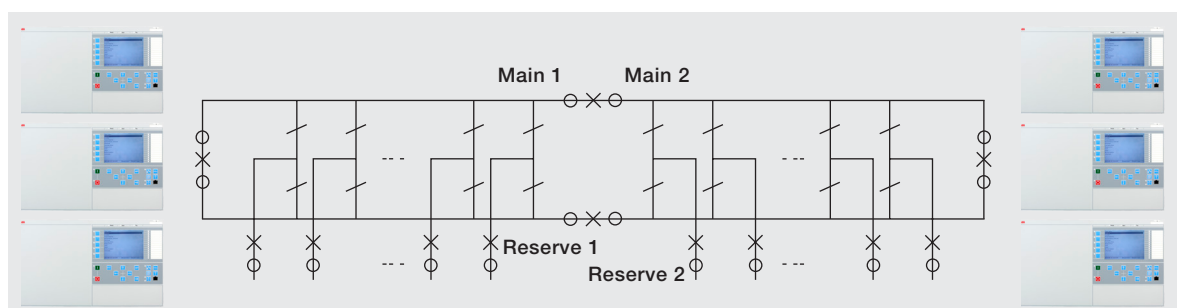

Double busbar – single breaker station with two bus-coupler CBs and two bus-section CBs.



Furthermore, overcurrent protection provides back-up protection for feeders. This function can also be applied for end-fault protection, i.e. detecting short-circuits between the feeder circuit breaker and feeder CT when the circuit breaker is open. This functionality together with the communication capabilities of REB670 allows for the sending of a fast overcurrent trip signal to the remote end, thus preventing an unnecessary trip from the busbar differential protection function.

The autoreclosing function is available to perform delayed busbar restoration after busbar protection operation.

Fast and efficient system integration

REB670 utilize ABB's unique connectivity package concept, which simplifies system engineering and reduces the risk of errors in system integration. This package contains a complete description of the specific IED, consisting of data signals, parameters, addresses and IED documentation.

The signal data is configured automatically based on the information provided by the connectivity package to efficiently integrate the IEDs into ABB's MicroSCADA Pro automation system.

Relion® 670 series support IEC 62439 standard redundant communications on the station bus. The solution from ABB utilizes the IEC 62439-3 standardized Parallel Redundancy Protocol (PRP). PRP improves the communication system reliability and features a unique capability of zero seconds' recovery time in case of communication failures. This means that there will be no interruption in communication if one link fails as the other link instantaneously takes over the communication. As a result, there is no data lost when communication failures have occurred.

The supervision of communication links provides real-time status information about both communication links individually. If a failure occurs, an alarm is sent to the IED HMI and the substation automation system. This also allows for maintenance of the station bus while it is in operation. Thus, redundant communication further improves personnel safety and ensures that the necessary information about the system is available for operators in all situations.

High impedance differential busbar protection

REB650

ABB offer a unique and compact solution for high impedance differential protection. The numerical busbar protection REB650 provides its users with a wide variety of application opportunities. Designed primarily for the protection of single busbars with or without sectionalizers in high impedance based applications, it also offers high impedance differential protection for generators, autotransformers, shunt reactors and capacitor banks. Its I/O capability allows you to protect up to three 3-phase high impedance differential protection zones with a single IED.

REB650 ensures fast fault clearance for all types of internal phase-to-phase and phase-to-earth faults in solidly earthed or low impedance earthed power systems. It can also handle all internal multi-phase faults in isolated or high impedance earthed power systems.

REB650 – ease of use from ready-to-use solutions

REB650 offers an optimum ‘off-the-shelf’ ready-made solution for applications requiring high impedance differential protection.

The type tested REB650 is delivered equipped and configured with complete protection and control functionality, and with default parameters for easy handling of products – from ordering, engineering and commissioning to reliable operation.

The 650 series introduce a number of innovations, such

as a significantly reduced number of parameter settings and extended IED HMI functionality, including 15 dynamic three-color indication LEDs per page, on up to three pages, and configurable push-button shortcuts for different actions. In the 650 series, most basic parameters are set before delivery from the factory. You only need to set the parameters specific to your application. This allows you to quickly take your IEDs into operation. The application manual includes setting examples to support your protection engineers.

The REB650 continues ABB’s strong track record in high impedance differential busbar protection applications, starting from analog relay RADHA and other similar relays from previous generations. To date, these relays have been successfully serving utilities for over 50 years.

Unique functional integration

One REB650 is able to handle several high impedance differential protection zones. For instance, you can use it for one or up to three zones depending on your application. You can also utilize it to combine two main zones and a check zone in a single IED.

Among its top-notch features, REB650 incorporates complementary protection functionality consisting of versatile current and voltage protection functions. These functions can be used independent of the high impedance differential protection. Thus, one REB650 can integrate all protection functionality needed for a bus coupler. If required, the busbar

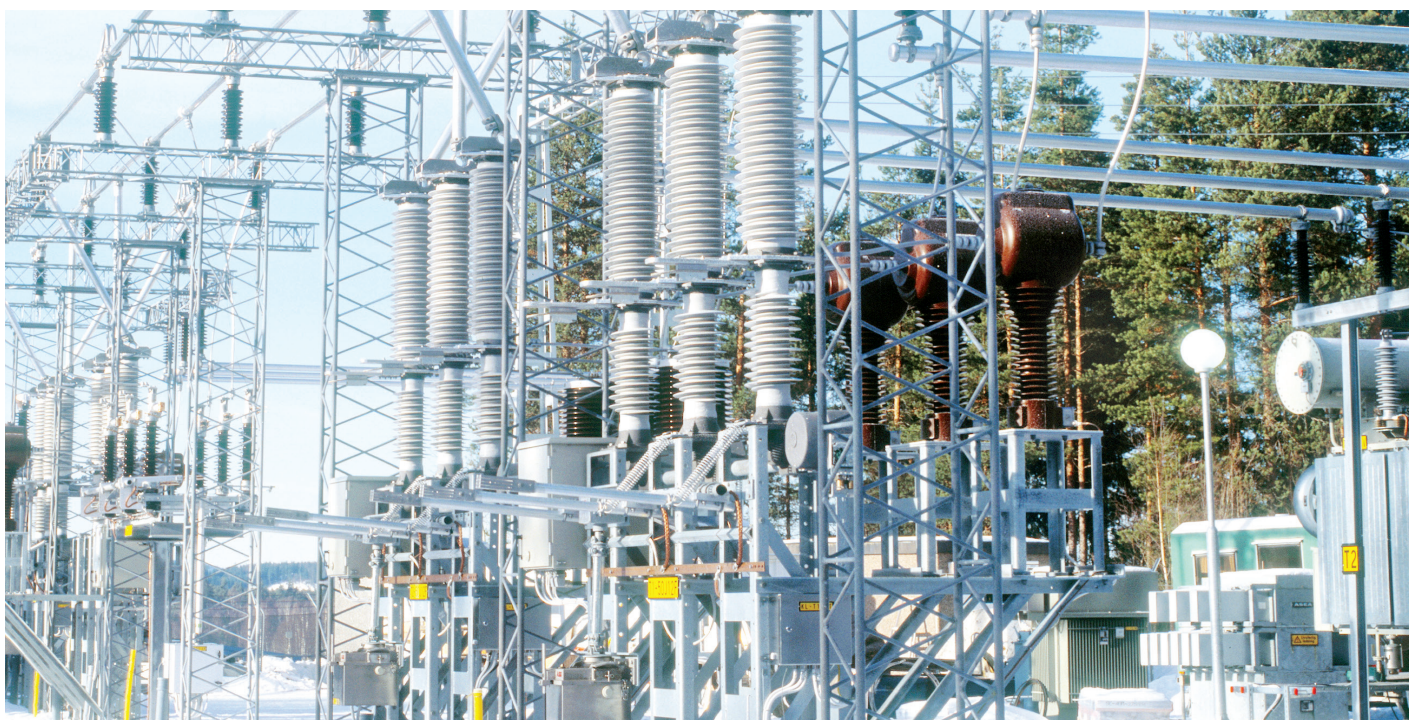



protection operation can be released using the integrated phase undervoltage or residual overvoltage protection functions as an additional tripping criterion.

The users of REB650 will also benefit from the powerful integrated disturbance recorder that stores up to 100 disturbances. The pickup settings made directly in CT secondary volts reduce the need for re-calculating the current pickup and resistor values. This is another fact that contributes to taking the IED into operation faster than ever before.

Designed to communicate

Relion® 650 series support IEC 62439 standard redundant communications on the station bus as per IEC 61850 standard. The solution from ABB utilizes the IEC 62439-3 standardized Parallel Redundancy Protocol (PRP). In addition, REB650 features several communication protocols, such as IEC 61850-8-1.

It utilizes ABB's unique connectivity package concept, which simplifies the system engineering and reduces the risks of errors in system integration. A connectivity package contains a complete description of the specific IED, consisting of data signals, parameters, addresses and IED documentation. The signal data is configured automatically based on the information provided by the connectivity package to efficiently integrate the IEDs in ABB's MicroSCADA Pro automation system.

Application examples

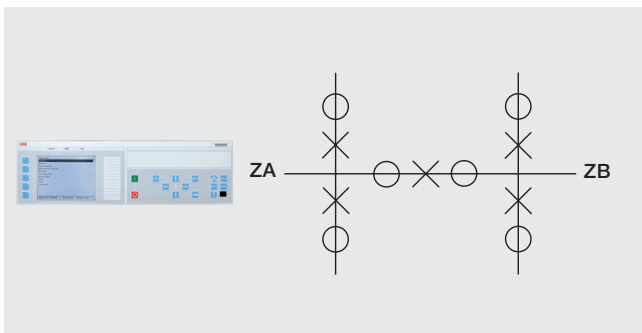

H-type station.

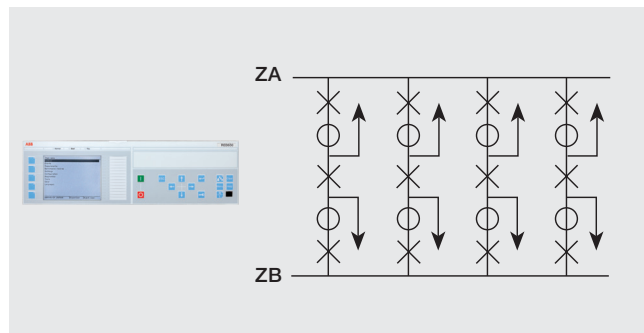

1 1/2 breaker stations.

Distributed busbar protection

REB500

REB500 IEDs provide reliable and proven busbar protection for different switchyard configurations. Additionally, by integrating a versatile selection of protection functions, REB500 IEDs protect the complete bay. This allows you to achieve optimized protection for your switchyard. Furthermore, REB500 is adaptable and scalable to your changing needs during the whole life cycle of your installation.

The IEC 61850 enabled REB500 IED is designed to support different protection philosophies. You can create a distributed protection solution by assigning bay units into dedicated bay cubicles. In this distributed solution, the bay protection is assigned to separate bay units. Alternatively, you can integrate all necessary functionality into one cubicle.

The versatile hardware and distributed functionality of REB500 IEDs allows for application in all types of switchyard configurations such as single busbar, double and triple busbar including transfer bus, quadruple and 1½-breaker schemes.

Stable and secure

REB500 detects all bus faults and feeder faults in solidly and low-impedance earthed power systems. It also detects all types of phase faults in isolated and compensated power systems.

REB500 busbar protection detects and operates selectively



for all faults in the protected zone. At the same time it maintains complete stability for faults outside the protected zone.

The integrated overall check zone feature is independent of isolators' indications. This feature enables REB500 to remain stable in case the busbar replica is not valid.

REB500 is capable of protecting busbars in all circumstances. It features a unique signal prolongation which enables continuous measurement and ensures correct operation of the busbar protection, even when the current transformers are heavily saturated during external faults. Two independent algorithms, stabilized differential current and directional current comparison, are utilized. This ensures correct operation of the busbar protection instead of blocking the protection function and leaving the busbar unprotected.

Additionally, REB500 maximizes the protected area within the substation in case the retrieved process data is not valid.

Versatile protection application capabilities

In addition to low-impedance busbar differential protection, REB500 integrates a comprehensive back-up protection functionality as well as station protection as an option.

Back-up protection includes both breaker failure and end-fault protection, which reduces the required wiring in the cubicle. Furthermore, less cabling is needed in the substation.

Station protection offers line distance protection and protection for 2- or 3-winding transformers integrated in bay units. Combined with busbar differential protection, a complete protection system can be built using one central unit and one or several bay units. The five zone line distance protection for phase-to-phase and phase-to-earth faults enables protection of different overhead line and cable applications using different system earthing principles.

Distributed installation

REB500 busbar protection can be installed distributed, which means that the busbar protection functionality is divided into several IEDs placed in bay-specific cubicles. These cubicles can be located close to the primary process. The IEDs exchange information using a fiber-optic communication link. Due to the short distance between IEDs in bay-specific cubicles and the primary process, the length of cables can be significantly reduced. This in turn simplifies maintenance and testing.

REB500 configuration process

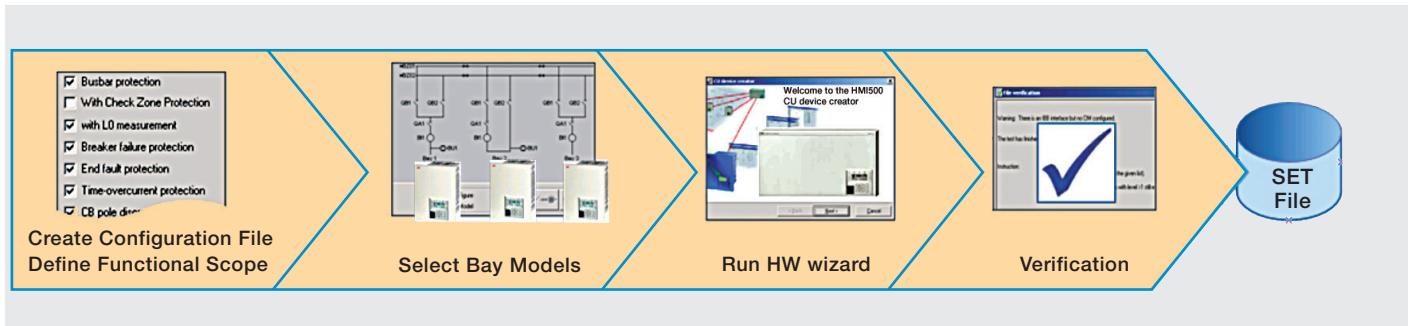

The workflow to create a typical configuration consists of four steps.

Easy access to substation information

REB500 gather vital process information and make it easily available for the user. For instance, disturbance information from each bay is available with a sampling rate of up to 2400 Hz. The information can be accessed via the local HMI of any of the REB500 IEDs in the protection system. Through REB500, process data can be made available, for example, for substation automation systems over IEC 61850-8-1 to necessary actions.

Process data can also be accessed by connecting a PC to the IED using the HMI500 tool, or using a standard internet browser to read data available in the REB500.

Adaptable to changing needs

REB500 adapts to changing needs throughout the life cycle of the substation. The scheme of the protection system can easily be adapted according to changes in the substation by adjusting the parameters in the IEDs. As REB500 uses the low-impedance principle, no additional interposing CTs are required. Functionality of the IEDs can also be upgraded without the need to change hardware.

REB500 also offers flexible solutions at system extension. With its capacity of up to 60 feeders and up to 32 busbar zones, the REB500 busbar protection system can grow according to your needs. Using the bay models from the bay model catalogue of the HMI500 tool as a base simplifies extension of the system.

The HMI500 tool offers a comprehensive and easy-to-use graphical user interface for handling the distributed busbar protection REB500 throughout its life cycle. The Online Help function adds to user comfort. The tool allows you to configure and set parameters for the complete station protection system.

The two variants of the tool have been optimized to provide the functionalities needed for different purposes. HMI500 Operation tool offers a wide range of functionalities, such as setting and retrieving parameters, event and disturbance handling, documentation of the configuration, and maintenance and testing of REB500. Password-based user management prevents access by unauthorized persons.

HMI500 Configurator offers functionality to fully configure the entire busbar protection application with REB500. The HMI500 Configurator tool utilizes a bay model catalogue. The catalogue consists of pre-configured bay models which allow you to maximize the working efficiency with the REB500 IED and the complete busbar protection system. The bay models are available for the most common busbar layouts such as single, double busbar with and without transfer bus as well as for triple busbar. The sophisticated compare configuration function provides detailed information about differences and changes made.

The HMI500 tool enables you to also create configurations based on the bay models. Furthermore shifting of bays or swapping the CT and breaker in couplers in existing configurations is supported.

Distributed busbar protection

REB500



IEC 61850-enabled

REB500 supports ABB's Relion® protection and control product family by offering a reliable solution for distributed busbar protection with station protection capabilities. Being IEC 61850-enabled, REB500 communicates over IEC 61850-8-1 and seamlessly interoperates with Relion IEDs in an IEC 61850-based system.

Improved communication

REB500 supports IEC 62439 standard redundant communications on the station bus as per the IEC 61850 standard. The solution from ABB utilizes the IEC 62439-3 standardized Parallel Redundancy Protocol (PRP). PRP improves the reliability of the communication system, and features a unique capability of zero seconds' recovery time in case of communication failures. This means that, if one link fails, the other link instantaneously takes over the communication. There will be no interruption in communication and no data will be lost.

The supervision of communication links provides real-time status information about both communication links individually. If a failure occurs, an alarm is sent to the IED HMI and the substation automation system. This also allows for maintenance of the station bus while it is in operation. Thus, redundant communication further improves personnel safety and ensures that the necessary information about the system is available for operators in all situations.

REB500 can also support synchronized sampled measured value communication over the process bus using IEC 61850-9-2 LE which replaces conventional wiring between the

process and the secondary system. This enables new design of substations. For example, utilization of sensor technology eliminates problems caused by, for instance, CT saturation and EMC influence. Furthermore, extensions and maintenance of substations can be completed more efficiently as fiber optic cables are used instead of copper wires.

REB500 allow you to mix conventional wiring and fiber optic communication with IEC 61850-9-2 LE in a REB500 protection system. This way you can shift step by step from conventional wiring for analog data to fiber-optic-based communication for synchronized sampled measured values.

Feature summary HMI500

Features	Operator	Configurator
Event monitoring	•	
Disturbance handling	•	
Read and write set file	•	
Online test	•	
Online monitoring	•	
Parameter setting	•	•
Signal matrix	•	•
Substation automation communication	•	•
Reports	•	•
Create application configuration		•
Import bay model		•
Adapt application configuration		•
Customize bay model		•

Application examples

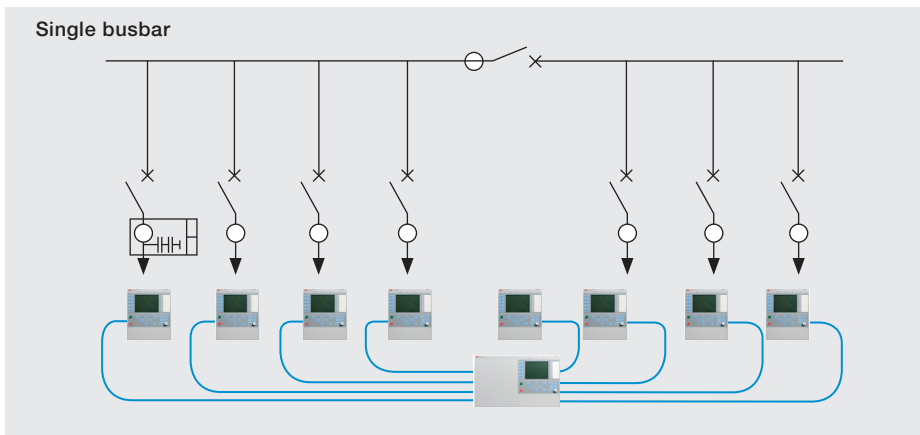

REB500 provides complete protection for a single busbar arrangement, and for a mixed mode configuration with conventional and non-conventional transformers. The mixed mode applies to all applications.

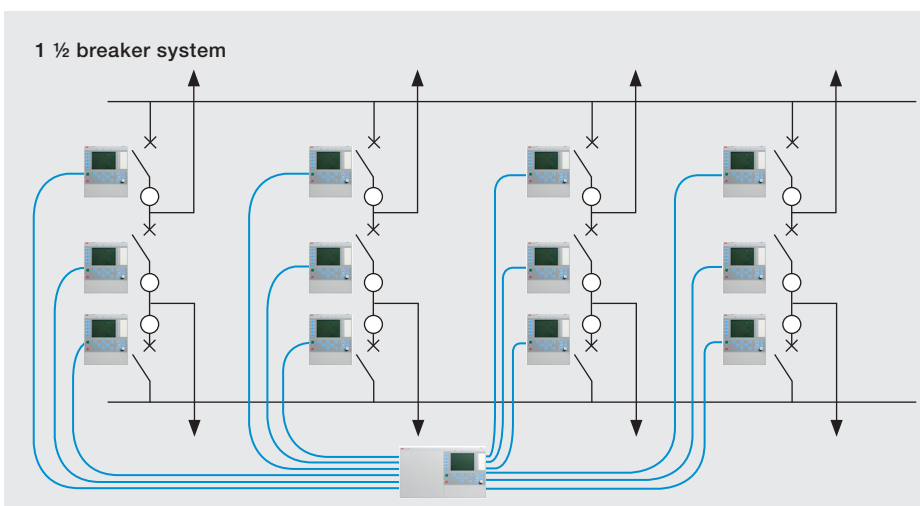

REB500 provides complete protection for a 1 ½ breaker system.

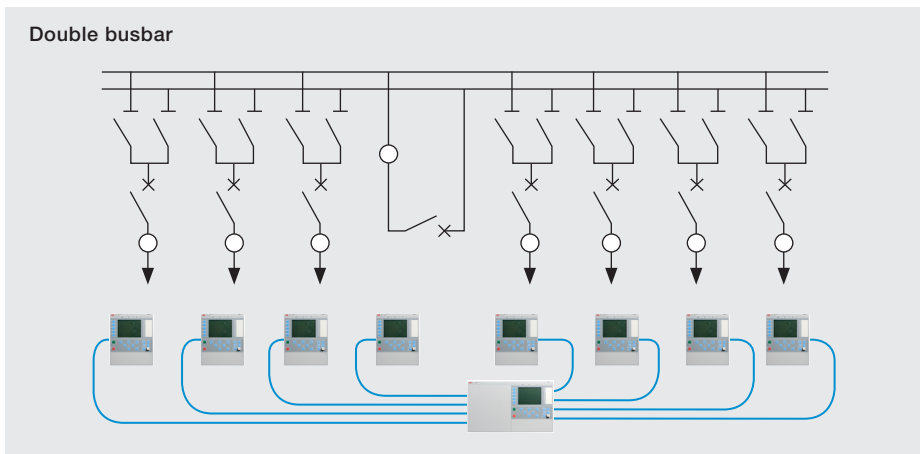

REB500 provides complete protection for a double busbar arrangement.

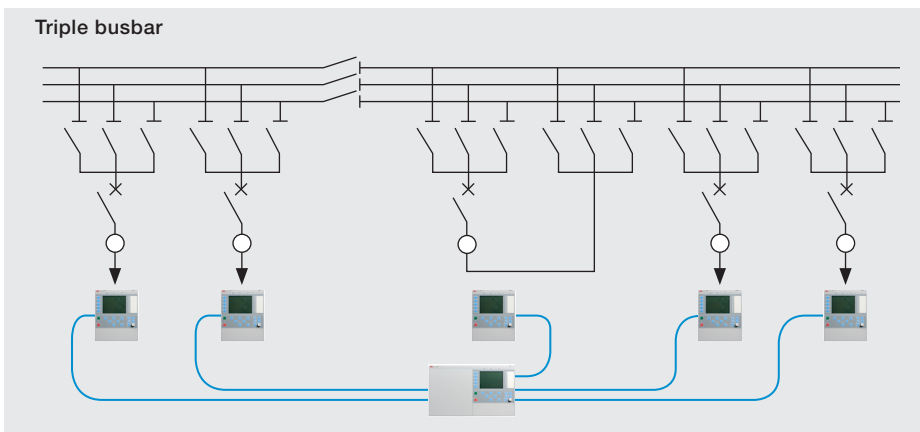

REB500 provides complete protection for a triple busbar arrangement.

Bay control REC670/650

The REC670 and REC650 are designed for the control, monitoring and protection of circuit breakers, disconnectors, and earthing switches in different switchgear configurations. Providing extensive application opportunities, both these IEDs are designed for IEC 61850. They implement the core values of this standard, which ensures open, future-proof and flexible system architectures, with state-of-the-art performance. The IEDs are therefore ideal for refurbishment and extension of existing installations as well as for new installations.

REC670 – maximum flexibility and performance

The REC670 provide customized or pre-configured control solutions for any type of switchgear and for different switchgear configurations. The customized REC670 gives you the freedom to select the functionality entirely according to your needs. The REC670 variants simplify handling since the basic functionality is included and pre-configured. If needed, you can add optional functions to easily increase the functionality of the REC670 to meet the specific requirements of your switchyard.

REC670 enables the manual control of a tap-changer from a Substation Automation system. It can also integrate advanced voltage control for transformers in a substation in a single IED. This eliminates the need for dedicated voltage control devices in cases where the transformer protection is not equipped



with voltage control.

REC650 – ease of use from ready-to-use solutions

REC650 offers optimum ‘off-the-shelf’ solutions for control applications in single breaker applications in single and double busbar arrangements. For double busbar arrangements, control of a bus coupler bay is also available. The type-tested variants are equipped and configured with complete functionality, and with default parameters for easy handling of products – from ordering, engineering and commissioning to reliable operation.

The 650 series has significantly reduced parameter settings and extended IED HMI functionality including 15 dynamic three-color-indication LEDs per page, on up to three pages, and configurable push-button shortcuts for different actions. In the 650 series, all basic parameters are set before delivery from the factory. You only need to set the parameters specific to your application, such as line data. This allows the IEDs to be quickly taken into operation.

Outstanding control capabilities

The bay control IEDs feature a large HMI for local control and instant access to important data, such as settings, events and disturbance information. It also provides a quick overview of the status of the bay with position indications and service values. You can freely select which of the measurements available in the IEDs should be shown on the HMI of the IEDs.

You can control and visualize locally up to thirty primary apparatus in up to six bays with REC670, and up to eight primary apparatus in one bay with REC650. The control is based on the select-before-operate principle, which ensures secure operation and helps avoid human error. By selecting the control screen (single line diagram) as a default screen, you can quickly execute control commands, and see the most important values.

The IEDs feature three pages of alarm indications and each page consists of 15 dynamic three-color indication LEDs. These three-color LEDs can present the status of any binary input signal on the HMI of IEDs.

The outstanding I/O capability of REC670 enables the control of several bays with complete measurement with only one IED. For instance, one REC670 IED is capable of handling the control of all apparatus in one entire diameter in an 1 ½ breaker arrangement, including breaker failure protection for all breakers. REC670 therefore simplifies system design and ensures extremely cost-efficient solutions for any substation at any voltage level supporting different protection and control

philosophies.

Additionally, REC670/650 features the two-position versatile switch and the 32-position selector switch functions, which enable you to easily manage switching operations via an icon on the HMI. The versatile switch function allows you to directly change, for instance, the autorecloser function from On to Off, or vice versa, without changing the configuration. This function also presents an indication of the selected position. The selector switch can replace an external mechanical selector switch and allows you to directly select the position you desire, for instance to change the autorecloser mode between 1-pole, 3-pole or 1- and 3-pole modes in REC670. In addition to the IED HMI, these switch functions can be operated from a remote system.

Secure interlocking

The advanced interlocking functionality of REC670 and REC650 IEDs allows you to avoid dangerous or damaging switchgear operations and to assure personnel safety. Both IEDs perform secure bay- and stationwide interlocking using easy-to-use reservation functionality. Reservation prevents simultaneous operation of apparatus and ensures that the interlocking information is correct at the time of operation.

Ready-made and tested interlocking modules are available for almost any type of switchgear arrangement. The interlocking scheme based on these modules can also be adapted to your specific interlocking conditions. These powerful IEDs support interlocking both via a station bus and hardwired signals. The bay control IEDs utilize GOOSE messaging based on the IEC 61850 standard to perform horizontal communication and interlocking. This provides a cost-efficient solution for the interlocking.

Operational reliability

In addition to interlocking, the output relays of the REC670 and REC650 IEDs feature an integrated continuous supervision function to ensure high security against unwanted operation. The Bay control IEDs are designed with the same technology as ABB's other 670 and 650 series protection and control IEDs. Meeting the stringent EMC requirements set for protection relays, these bay control IEDs provide secure control of your primary equipment.

Cost savings through integrated functionalities

Both REC670 and REC650 bay control IEDs feature breaker failure protection. This provides cost savings and improves availability since no separate breaker failure protection relays are needed. REC650 integrates breaker failure protection for one breaker in each device, and REC670 for breakers in any type of breaker arrangement in a single device. Integrated synchronizing functions, autoreclosing and back-up protection

Bay control REC670/650



functionality save both space and money. In addition, the integrated local HMI eliminates extensive cabling as the traditional mimic board with related interposing relays is not needed.

The capacitor bank protection in REC670 detects dangerous operation situations and trips before any damage occurs in capacitor units that are vulnerable to different phenomena in power systems.

The capacitor bank protection in REC670 consists of overcurrent protection, undercurrent protection, harmonic overload protection, reactive power overload protection and a reconnection inhibit function. These, together with other protection functions that can be included in REC670, such as unbalance protection based on overcurrent protection, provide complete protection for capacitor banks.

In addition to the wide range of overcurrent protection functions, REC670 and REC650 provide a negative sequence overcurrent protection. This function detects all unsymmetrical faults with or without earth connection. It features high sensitivity, which enables detection of faults with low fault current. The negative sequence overcurrent protection can also be used as directional. This facilitates the coordination with protection for other objects.

The four step negative sequence overcurrent protection can serve as back-up protection for most faults. It can also serve as the main protection for earth faults and other unsymmetrical faults.

The REC650 features extensive circuit breaker condition monitoring and monitoring of the station battery supply. The three trip circuit supervision outputs of the IED eliminate the need for an external trip circuit supervision unit.

Fast and efficient system integration

The REC670 and REC650 provide a compact, bay-oriented control solution with communication capabilities replacing conventional control circuits. Due to their IEC 61850 compliance, they can be easily integrated with any IEC 61850 compliant system. In addition, they can exchange information and cooperate with other vendors' IEC-61850-compliant IEDs.

Relion® 670/650 series IEDs support IEC 62439 standard redundant communications on the station bus as per IEC 61850 standard. The solution from ABB utilizes the IEC 62439-3 standardized Parallel Redundancy Protocol (PRP). PRP improves the communication system reliability and features a unique capability of zero seconds' recovery time in case of communication failures. This means that there will be no interruption in communication if one link fails as the other link instantaneously takes over the communication. As a result, there is no data lost when communication failures have occurred.

The supervision of communication links provides real-time status information about both communication links individually. If a failure occurs, an alarm is sent to the IED HMI

Application examples

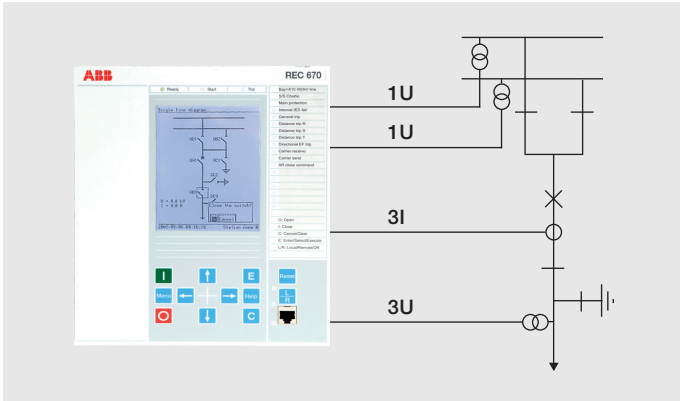

REC670/650 in a double busbar single circuit breaker arrangement.

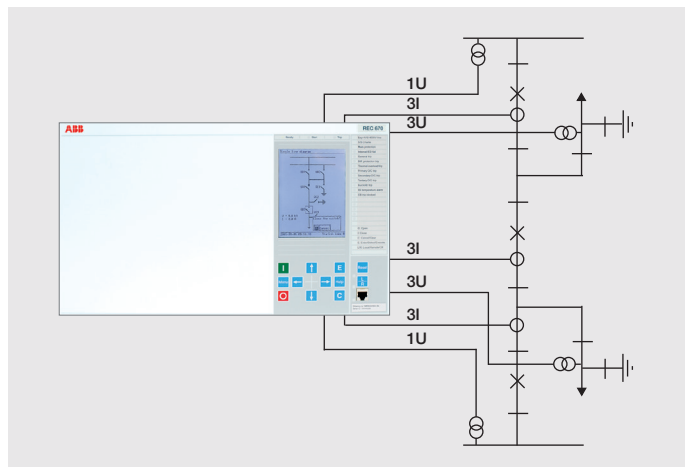
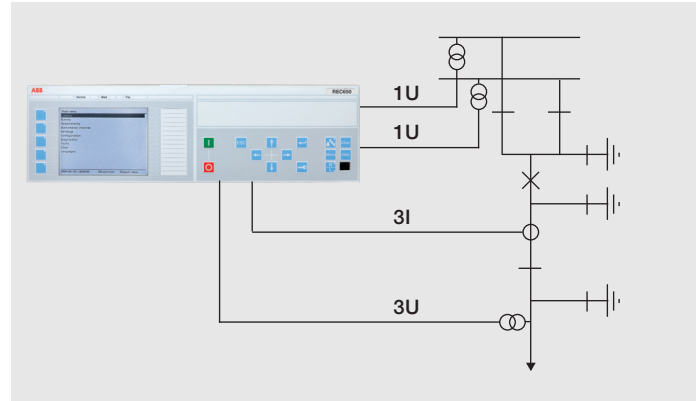

One REC670 is capable of handling control of all apparatus in one entire diameter in 1 1/2 breaker arrangement.

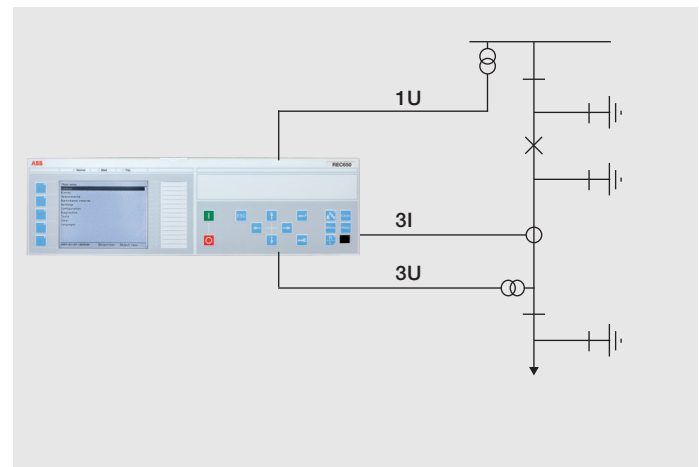

REC650 in a single busbar single circuit breaker arrangement.

and the substation automation system. This also allows for maintenance of the station bus while it is in operation. Thus, redundant communication further improves personnel safety and ensures that the necessary information about the system is available for operators in all situations.

Relion[®] 670 series IEDs can also support synchronized sampled measured value communication over the process bus using IEC 61850-9-2 LE which replaces conventional wiring between the process and the secondary system. This enables new design of substations. For example, utilization

of sensor technology eliminates problems caused by, for instance, CT saturation and EMC influence. Furthermore, extensions and maintenance of substations can be completed more efficiently as fiber-optic cables are used instead of copper wires.

670 series IEDs allow you to mix conventional wiring and fiber-optic communication with IEC 61850-9-2 LE in a single IED. This way you can shift from conventional wiring for analog data to fiber-optic-based communication for synchronized sampled measured values step by step.

Breaker protection REQ650



Breaker protection REQ650 provides a standalone solution for applications where the integration of the breaker failure protection or automatic reclosing function into the main line protection IED (Intelligent Electronic Device) is not preferred or suitable. This IED also offers local back-up protection, synchronizing, synchrocheck and energizing check functionality to enable well-structured and reliable protection for various applications.

REQ650 provides you with an ideal protection and control solution for circuit breaker connected objects. The breaker failure protection allows for high speed back-up tripping of surrounding breakers, and re-tripping of the own breaker in any single breaker busbar arrangement, for instance to avoid operational mistakes during testing. This function is essential in substations that require local back-up protection. Breaker protection REQ650 is also the perfect choice for refurbishment projects where old protection relays need to be replaced.

Versatile application opportunities

With its compact design and versatile functionality, REQ650 provides its users with a wide range of application opportunities.

For your existing protection systems, REQ650 enables an easy and cost-efficient way to add local back-up protection. The original main protection can remain in operation, while one REQ650 IED installed in parallel offers the necessary back-up functionality. At the same time, the integrated



disturbance recorder helps you improve your disturbance information handling.

In new substations in a meshed electrical power network, REQ650 enables cost-efficient local back-up protection with included additional basic protection and control functionality. In a line bay, the four-stage, directional phase overcurrent protection and four-stage, directional residual overcurrent protection can provide back-up protection for the line distance or line differential protection, provided by REL670/REL650 and RED670, for instance. Note that directional residual overcurrent protection can be either voltage or current or dual polarized with either zero or negative sequence quantities depending on your network grounding and your protection philosophy. With its automatic reclosing and synchrocheck functions, REQ650 can also be used as independent breaker control device for overhead-lines. Additionally, a number of other available voltage-, current-, power- and frequency-based protection functions are well suited for other applications, for example as back-up protection device in transformer, reactor and shunt capacitor bays.

In retrofit installations REQ650 can provide similar benefits, but also offers extended bay functionality by using built-in control, monitoring, recording, measurement and communication features.

In radially fed networks REQ650 can be used as main protection device also including control, monitoring, recording and communication functionality for all types of line and transformer bays.

Application examples

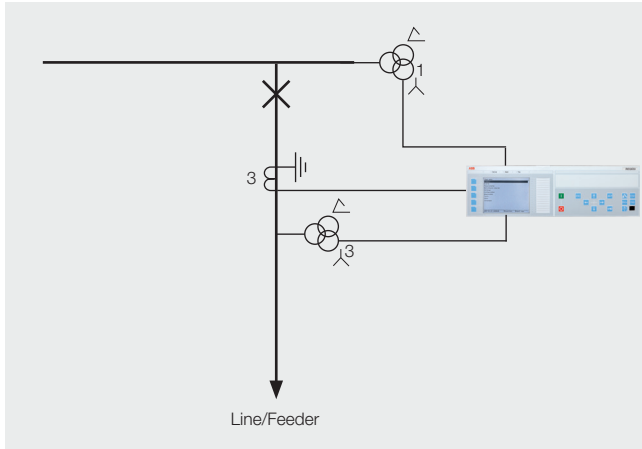

Line bay in solidly earthed network, connected to single busbar switchyard.

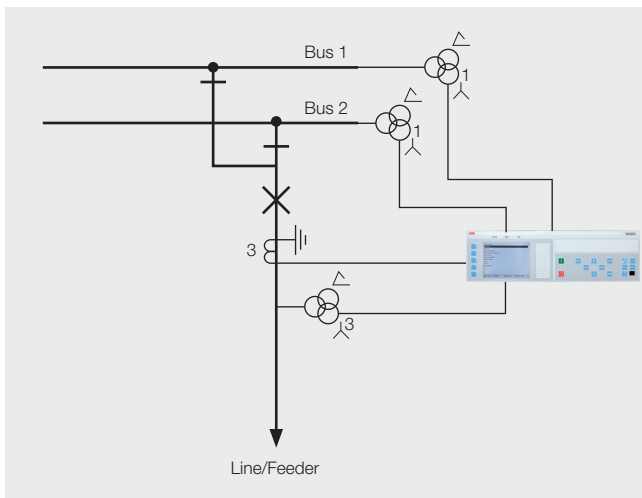

Line bay in solidly earthed network, connected to double busbar switchyard.

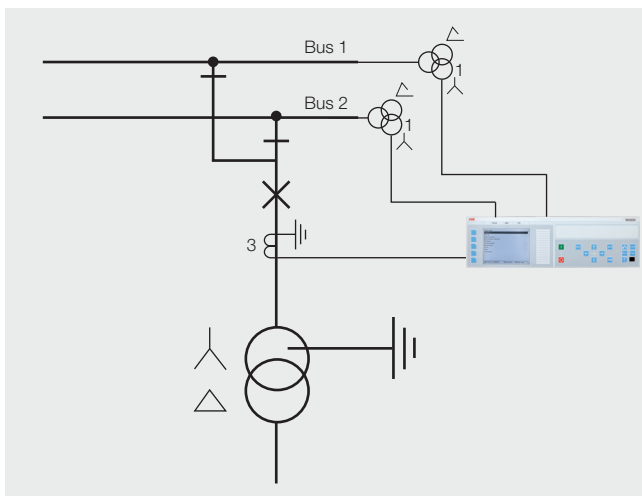

Transformer bay in solidly earthed network, connected to double busbar switchyard.

Long life with high availability

In aging installations, the remaining lifetime of existing protection equipment often varies considerably. In such cases a partial replacement and retrofit can provide a solution that saves both time and money.

In partial replacement the old, unreliable relays in line protection applications can be replaced with one REQ650 and combined with your well-functioning existing relays. Another possibility is to replace the breaker failure protection relay – often the weakest link in a well-functioning busbar protection system – with one REQ650 per bay. At the same time, a number of valuable additional functionalities will become available, including extensive back-up protection functionality, basic control functionality and a disturbance recorder.

Furthermore, the communication capabilities of REQ650 allow you to transfer data to your control center. REQ650 IEDs support IEC 62439 standard redundant communications on the station bus as per IEC 61850 standard. The solution from ABB utilizes the IEC 62439-3 standardized Parallel Redundancy Protocol (PRP). All in all, REQ650 helps increase both availability and the lifetime of an aging protection system.

REQ650 offers optimum 'off-the-shelf', ready-made application solutions for the protection and control of circuit breaker connected objects. The type-tested variants are delivered equipped and configured with complete protection functionality, and with default parameters for easy handling of products – from ordering, engineering and commissioning to reliable operation.

The 650 series IEDs introduce a number of innovations, such as a significantly reduced number of parameter settings and extended IED HMI functionality including 15 dynamic three color-indication LEDs per page, on up to three pages, and configurable push-button shortcuts for different actions. In the 650 series IEDs, most of the basic parameters are set before delivery from the factory. You only need to set the parameters specific to your application. The parameters related to the protected object are set as primary values, which significantly reduces the need to recalculate the current and voltage values. This allows the IEDs to be quickly taken into operation. The application manual includes setting examples to support the protection engineer.

Generator protection REG670/650

Based on ABB's in-depth generator protection knowledge, REG670 and REG650 take generator protection to a new performance level that ensures unrivalled selectivity and sensitivity. REG670/650 provide protection and monitoring for generators, prime movers and step-up transformers in hydro, pump-storage, gas, diesel, combined-cycle, steam, nuclear, cogeneration and renewable power stations. With excellent performance, flexibility and scalability, they fulfill the demanding requirements of both new and retrofit installations – in every corner of the world.

A generator protection system with REG670/650 meets the requirements for maximum dependability and availability. The differential protection internal/external fault discriminator is based on negative sequence current values, enabling fast and selective decision to operate. The unique main protection functions are able to selectively detect and clear all fault types over 100% of the stator winding. The detection criteria can

be used to create intelligent, application-specific functions to enhance your protection system, enabling it to meet very specific requirements, for instance, when the operating conditions of the plant change.

REG670/650 place low requirements on instrument transformers, which, together with the fast and accurate protection functions, reduces primary equipment demands and investment costs.

REG670 – for any type and size of generator and generator-transformer unit

REG670 provide customized and pre-configured protection solutions for any type of generator and block connected generator-transformer unit. Due to its unique capabilities it is especially suitable for protecting large turbo and hydro units including pump-storage power plants.

The pre-configured and type-tested IEDs simplify the handling

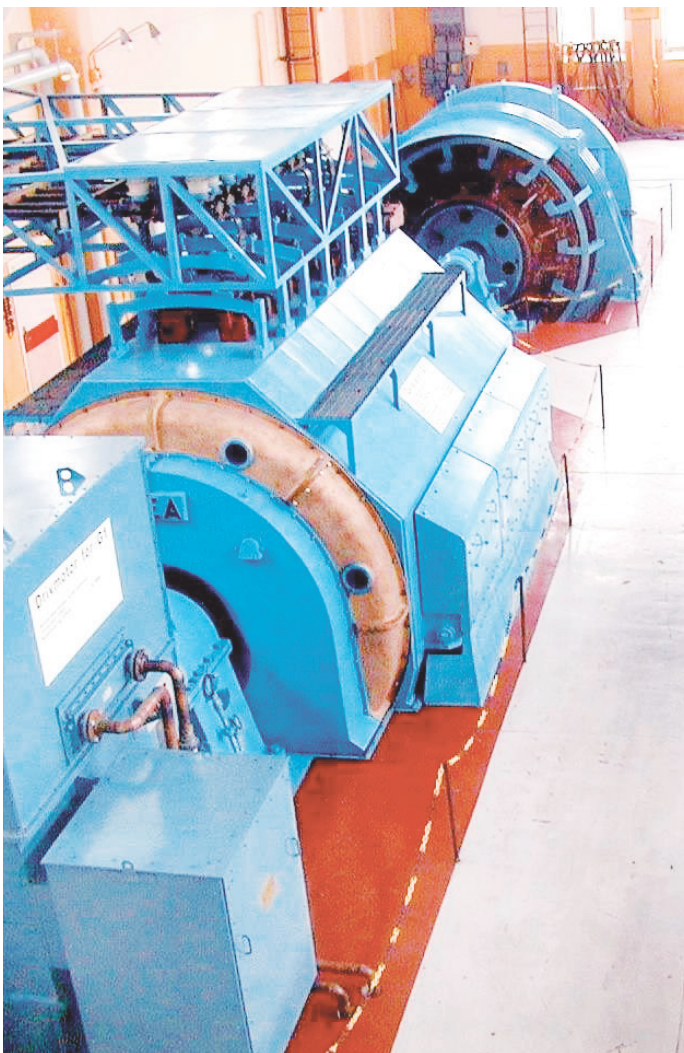

of products – from ordering, engineering and commissioning, to reliable operation. If needed, additional I/O boards, communication options or application functions can easily be added to meet the specific requirements of your generating station. Furthermore, several instances of protection functions are readily included in the REG670 IEDs, and these are activated by parameter settings during commissioning.

The pre-configured REG670 variants simplify handling since the basic functionality is included. If needed, you can add optional functions to increase the functionality of the pre-configured REG670 IEDs to meet the specific requirements of your power plant. The customized REG670 gives you the freedom to select functionality entirely according to your needs.

The generator differential protection of REG670 features extremely fast detection criteria, with a typical operate time of 15 ms – and yet the IED maintains high security. The transformer/unit differential protection integrated in REG670 provides extremely fast differential protection with automatic ratio matching and vector group compensation. Additionally, it takes the tap-changer position into consideration for optimized sensitivity. Utilizing the same transformer differential protection used in Transformer protection RET670 allows REG670 to be a complete protection solution for generator-transformer units.

Unique functional integration

REG670 integrates parallel algorithms with advanced logic and communication. Up to 24 analog inputs permit integration of main and back-up protection in one IED. This allows you to protect several objects with a single REG670 IED. For instance, by integrating several differential protection functions, one single REG670 IED can protect a complete generator-transformer unit. The underimpedance protection function can also be used as back-up protection for faults within the unit or external faults in the power network.

Alternatively, additional objects, such as transformers, can be included in the generator protection scope. This enables full duplication of the protection in main one and main two. All this reduces the number of IEDs needed to protect the entire generating station, increasing availability at the same time. The selector switch can replace an external mechanical selector switch which allows you to directly select the position you desire. In addition, these switch functions can be operated from a remote control system.

Versatile communication capabilities

REG670/650 IEDs allow you to use several communication protocols in parallel to communicate with the plant control system, monitoring system or relay protection engineering office. They are designed for IEC 61850, implementing all aspects of this standard and thus ensuring open, futureproof and flexible system architectures, with state-of-the-art performance. These capabilities also provide new opportunities for utilizing signalling and tripping schemes in generator protection. Additionally, they enable the transfer of binary and analog data to any subscriber.

Relion® 670/650 series IEDs support IEC 62439 standard redundant communications on the station bus as per the IEC 61850 standard. The solution from ABB utilizes the IEC 62439-3 standardized Parallel Redundancy Protocol (PRP). PRP improves the communication system reliability and features a unique capability of zero seconds' recovery time in case of communication failures. This means that there will be no interruption in communication if one link fails as the other link instantaneously takes over the communication. As a result, there is no data lost when communication failures have occurred.



Generator protection REG670/650



This in turn simplifies the installation and reduces its lifecycle cost from commissioning to maintenance and spare parts.

The dedicated measurement class input current transformers of REG670 enable detection of power level down to 0.5% of the unit rated power, which ensures accurate reverse power protection in steam-turbine applications.

In demanding applications, such as pump-storage plants, the unit has several operating modes: generating, pumping, starting or breaking. In such applications, the protection IED needs to adapt to the actual operating mode. The logical programming capability of the REG670 allows it to automatically detect the actual operating mode of the unit and adapt its operation accordingly. The selected operating mode can be shown on the built-in HMI, which is useful especially during commissioning and testing.

The distance between the generator and the high voltage substation can in many cases be substantial and yet many binary signals need to be exchanged between the two locations. REG670 features a dedicated fiber optic communication link to exchange binary signals with another 670 series IED located in the high voltage substation. Up to 192 binary signals for indication, alarming and tripping purposes can be sent in both directions simultaneously.

REG670 also features injection-based 100% stator earth-fault protection and 3rd harmonic based 100% stator earth-fault protection. These solutions enable a new way to optimize the cost-performance ratio of the protection system in relation to the importance or size of the generating station. The 3rd

harmonic based 100% stator earth-fault protection utilizes the differential principle, which provides high sensitivity and security. This ensures correct operation even during low load conditions.

Stator and rotor protected under all operating modes

REG670 provides stator and rotor overload protection through continuous monitoring of actual current compared with the design standard (IEEE-curve). This enables unique possibilities for measurement and disturbance recording of rotor DC current., hence it helps to detect abnormalities in the excitation equipment. Also, these functions enable simple retrofit of REG216/316.

The multipurpose filtering function detects and analyzes power system current and voltage signals in order to extract preset frequency signals. This allows for detection, alarm, and tripping at special operating conditions, such as sub-synchronous resonance in the system and consequently prevention of low frequency axial oscillation in generators. This resonance can be high in series compensated systems. Prevention of oscillation minimizes generator maintenance and downtime.

When the injection-based protection of REG670 is used, 100% of the machine stator winding, including the star point, is protected under all operating modes, even at machine standstill. The innovative filtering technique enables high sensitivity for both stator and rotor protection, which enables early detection of faults.

Additionally, ABB's innovative implementation of the injection principle does not require any changes in the plant primary

circuit because injection is always done on the secondary side of the voltage or grounding transformer irrespective of the actual grounding method used. This enables very cost-efficient design of the injection unit, and makes it very easy and fast to take the protection system into operation. Thus REG670 offers an optimum solution for large hydro and turbo machines.

A special tool module accessed via Protection and control IED manager PCM600 significantly simplifies the commissioning and operation of the injection-based stator and rotor earth-fault protection functions. Additionally, the tool module guides the user through the installation and calibration procedure to achieve sensitive protection.

At the end of the calibration process the tool verifies the validity of the calibration parameters which ensures proper operation of the installation taking into account all the characteristics of the installation.

REG650 – your best choice for small and medium-sized generators

REG650 offers optimum 'off-the-shelf', ready-made solutions, including all the required functionality for protection and control of small and medium-sized generators. With its 20 analog inputs, REG650 is one of the most compact generator protection devices on the market. This allows, for instance, the integration of overcurrent protection for excitation or auxiliary transformer, in addition to generator protection. The

3rd harmonic based 100% stator earth-fault protection utilizes the differential principle, which provides high sensitivity and security. This ensures correct operation even during low load conditions.

The variants of REG650 IEDs are delivered equipped and configured with complete functionality and with default parameters for easy handling of products – from ordering, engineering and commissioning to reliable operation. Depending on the selected variant, either low impedance generator differential protection or three winding transformer differential protection is included. Other generator protection functions are always included.

The 650 series IEDs introduce a number of innovations, such as a significantly reduced number of parameter settings and extended IED HMI functionality, including 15 dynamic three color-indication LEDs per page, on up to three pages, and five configurable function keys for different actions. In the 650 series IEDs, most basic parameters are set before delivery from the factory. You only need to set the parameters specific to your application.



Generator protection

REG670/650

The right information for the right action

The integrated HMI of REG670 and REG650 provides you with a quick overview of the status of the power plant with position indications and service values. Using a library of symbols, you can easily configure the graphical display to correspond to your needs and to your station. The built-in disturbance recorder, capable of storing data in COMTRADE format, provides you with valuable data for post fault analysis and corrective actions to increase the security of your power plant.

The two-position versatile switch and 32-position selector switch functions of REG670/650 IEDs enable you to easily manage switching operations via an icon on the IED HMI. The functions also present an indication of the selected position.

Fast and efficient system integration

REG670/650 IEDs are more than just devices. They utilize ABB's unique connectivity package concept, which simplifies the system engineering and reduces the risks of errors in system integration. An IED connectivity package contains a complete description of the specific IED, consisting of data signals, parameters, addresses and IED documentation. Being designed for IEC 61850, it can easily be integrated in any power plant control system that is compliant with this standard.



Application examples

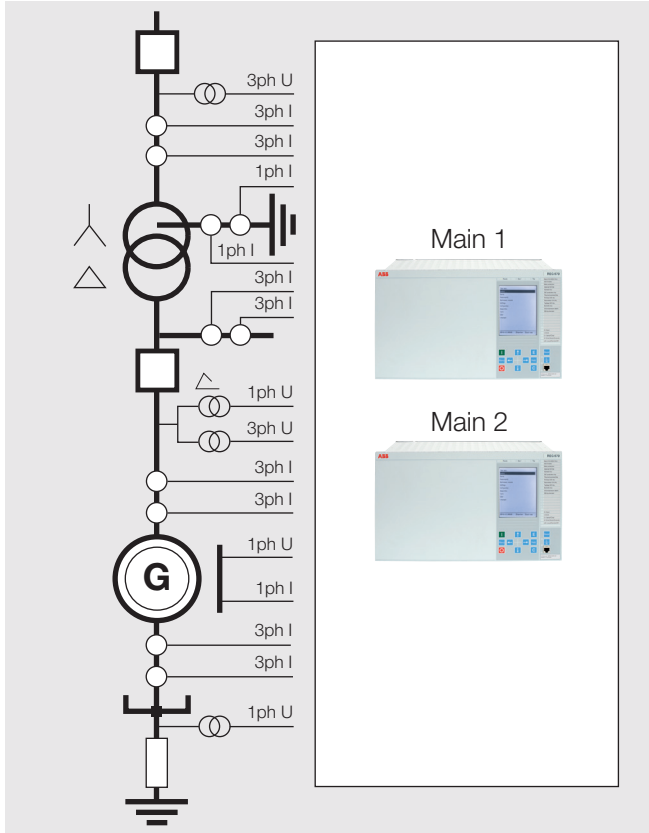

REG670 IED with 24 analog inputs is able to protect the entire generator-transformer unit including generator differential and transformer/overall differential protection. Redundancy is obtained by duplication.

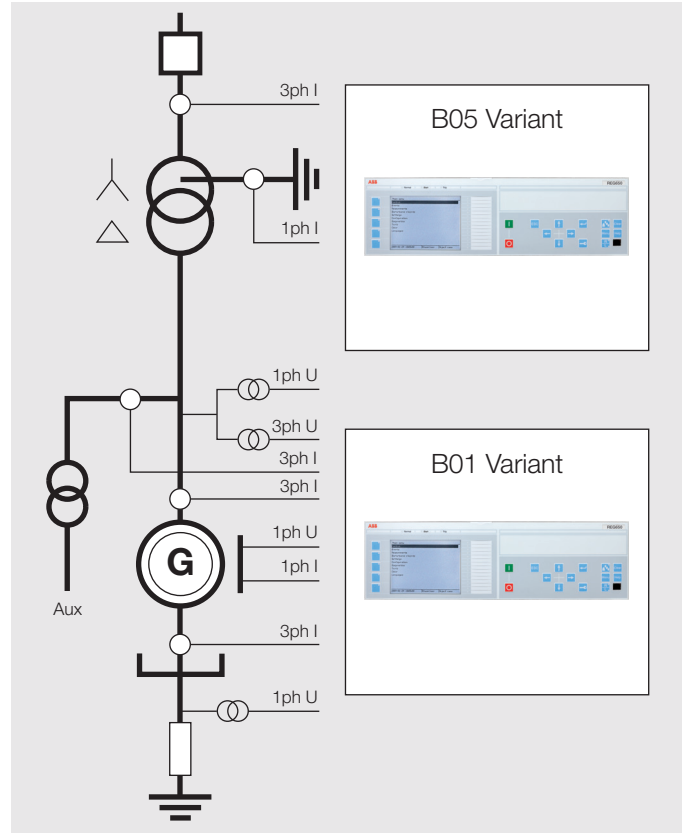

REG650 based protection scheme for medium-sized generator-transformer unit connected to a solidly earthed high voltage system.

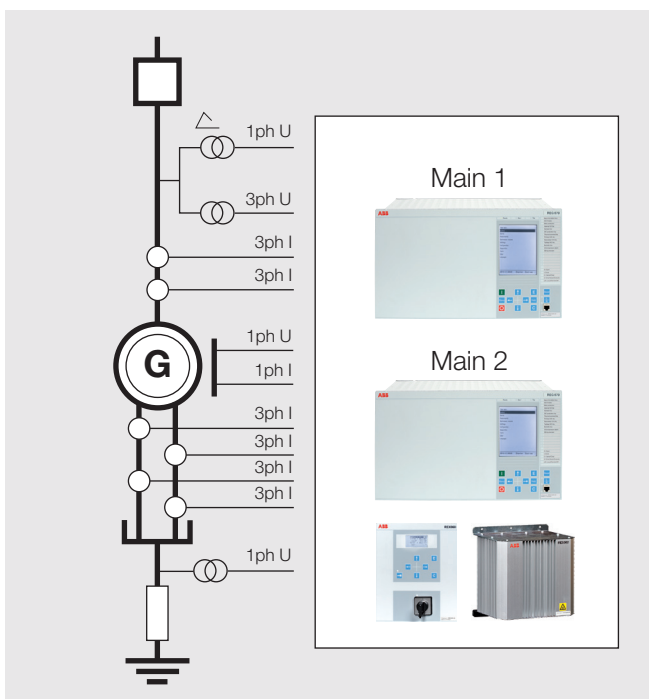

REG670 IED with 24 analog inputs for advanced generator protection including overall differential protection, split-phase differential protection and 100% stator earth-fault protection based on injection principle. Redundancy is obtained by duplication.

Wide area protection RES670



For real-time and efficient wide area power system monitoring, protection and control

The RES670 provides power system AC voltages and currents as phasors - up to 8 analog phasors with the possibility to send positive, negative, zero sequence values or all of them. Reference for the phase angle is the Global Positioning System - GPS or IRIG-B. The high measurement accuracy of voltages and currents eliminates the need for external measurement transducers. This makes RES670 ideal to use in all types of Phasor Measurement Unit (PMU)-based applications.

The communication capabilities of RES670 including IEEE C37.118, IEC 61850-8-1 and DNP3.0 enable easy integration of RES670 in an existing substation automation system. Further, along with the phasor data measurement functionality, several protection and control functions of the Relion® 670 series IEDs are available in RES670.

The RES670 also offers the operational flexibility for the challenges imposed by the Smart Grid applications of tomorrow.

RES670 IEDs provide customized or pre-configured measurement solutions applicable for any type of substation and substation configuration. The customized RES670 gives you the freedom to select functionality entirely according to your needs. The pre-configured RES670 variants simplify handling since the basic functionality is included and pre-configured.

Application



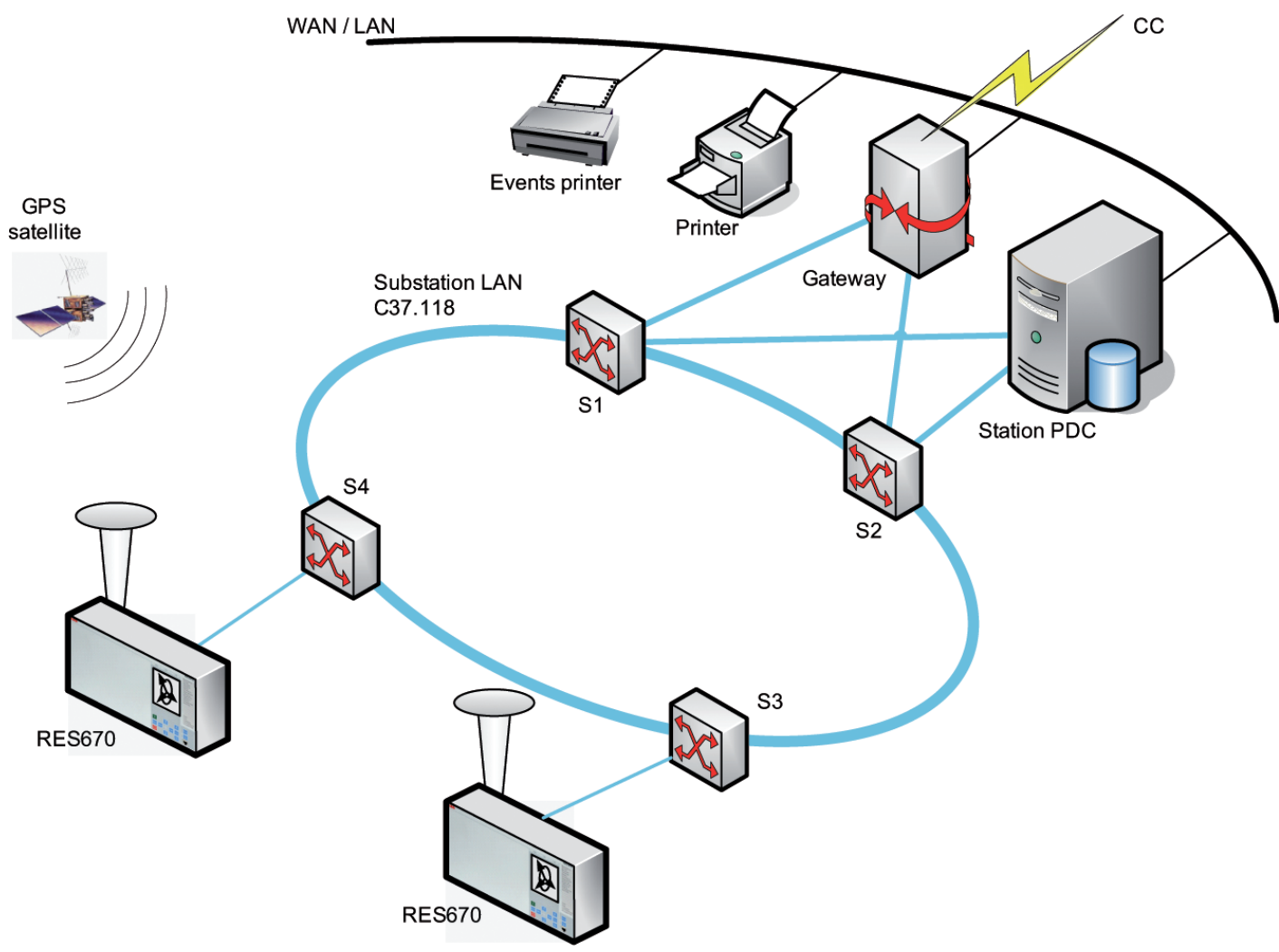

RES670 is a Phasor measurement unit that provides power system AC voltages and currents as phasors, that is as real and imaginary parts or as magnitude and phase angle. The reference for the phase angle is the NavStar Global Positioning System – GPS that also supplies highly accurate time and date. The accurate time tagging of measurements taken at different geographical locations make it possible to derive the synchronized phasor quantities. Based on synchrophasors a number of power system applications are available. Phasor Measurement Units (PMUs) have so far been mainly used for recording and on-line supervision of Wide Area Measurement System (WAMS) applications. In a typical setup, 10-20 PMUs at different locations in a synchronized power network, stream out the synchrophasor data along with the frequency and rate of change of frequency to a Phasor Data Concentrator (PDC).

In a Wide Area Monitoring System (WAMS) PDC normally collects, stores, transmits and analyzes critical data provided by PMUs from key points across the power networks and over large geographical areas. Data Storage is a key function of a PDC to archive historical process data from PMU devices and WAMS applications. Data sets can be stored in different resolutions and various time spans. The phasor data is normally sent from the PMU to the PDC at user selectable rates from 10 to 200/240 samples per second. Phasor data is normally understood as the magnitude and phase angle of the positive sequence voltage or current. The common reference for the angle measurement is the GPS system, which provides precise time reference. Since every measurement sent to the data concentrator is time tagged, any angle difference between power system AC quantities can be derived.

Relion® 670 series

– maximum flexibility and performance

The Relion® 670 series protection and control IEDs provide versatile functionality, as well as maximum flexibility and performance to meet the highest requirements of any application in generation, transmission and sub-transmission protection systems.

The 670 series IEDs include:

- Pre-configured and fully customized IEDs. As pre-configured, the IEDs are delivered type-tested and with default parameters to simplify ordering, engineering and commissioning. This shortens the time from delivery to operation. If needed, the IEDs can be easily adapted to meet specific power system requirements. The customized IEDs offer full flexibility in application engineering, allowing complete adaptation to your needs.
- Capability of handling several objects with a single IED and enable many other smart solutions based on functional integration. This multi-object capability has already been utilized by several utilities to increase availability and to optimize the cost-performance ratio while maintaining high grid reliability.
- Functionality required specifically in transmission applications, such as series compensation. They also feature both 1- and 3-phase tripping, voltage control for up to eight parallel transformers, an extended disturbance recorder, and binary and analog data transfer between IEDs.
- Powerful and flexible hardware designed for the highest EMC requirements
- Event list for 1000 events
- Disturbance report
- Event and trip value recorders
- Event counters
- Supervision of AC and mA input quantities
- HMI with fast display performance and virtual keyboard
- Programmable buttons and three color LED indications for fast handling of IED
- Unicode for character sets in any local language

Features

- Fully IEC 61850 compliant with Ed.1 and Ed.2 in the same IED
- Protection, monitoring and control integrated in one IED
- Extensive self-supervision including analog channels
- Six independent parameter setting groups
- Signal matrix for easy configuration of binary and analog signals
- Ethernet interface for fast and easy communication with PC
- Large HMI for visualization of single line diagrams
- Supports NERC cyber security requirements

Control functions

- Apparatus control for up to 30 apparatus
- Synchrocheck, energizing check and synchronizing
- Selectable operator place allocation
- Versatile switch with two positions
- Selector switch with up to 32 positions

Monitoring

- Disturbance recorder
 - Up to 10 seconds of data before the trigger
 - Up to 100 disturbances
 - 40 analog channels, 30 physical and 10 derived
 - 352 binary channels

Communication

- IEC 61850-8-1 including GOOSE messaging
- IEC 61850-9-2
- IEC 60870-5-103
- LON
- SPA
- DNP 3.0
- Remote end communication for transfer of 192 binary signals
- 62439-3 standardized Parallel Redundancy Protocol (PRP)

Setting, configuration and disturbance handling

- Protection and control IED manager PCM600
 - Installation and commission tool module for injection-based protection

Hardware

- Full 19" case, 6U height with 24 analog inputs and up to 11 I/O modules
- 3/4 case, 6U height with 24 analog inputs and up to 8 I/O modules
- Half 19" case, 6U height with 12 analog inputs and up to 3 I/O modules
- Power supply modules from 24 to 250 V DC \pm 20%
- Metering class input CTs
- Binary input module with 16 inputs
- Binary output module with 24 outputs
- Binary input/output module with 8 inputs and 12 outputs
- mA input module with 6 transducer channels
- GPS or IRIG-B time synchronization module
- Remote-end data communication modules
- Accessories

Relion® 650 series

– ease of use from ready-to-use solutions

The Relion® 650 series protection and control IEDs provide optimum ‘off-the-shelf’, ready-to use solutions equipped and configured with complete protection functionality and default parameters to meet the needs of a wide range of applications within generation, transmission and sub-transmission networks.

The 650 series IEDs include:

- Pre-defined functionality optimized to meet different requirements of sub-transmission applications.
- Complete application configuration ready-made at the factory. To adapt the IED to your specific needs, you can easily modify the default I/O connections.
- Flexible system configuration through integrated protection and control in one IED.
- High reliability through Parallel Redundancy Protocol (PRP).
- Support for user-defined names in the local language for signal and function engineering to enable easy understanding and user-friendliness when the protection and control system is in operation.
- Minimized parameter setting based on default values and ABB's new global base value concept. In addition parameter settings can be forced. This allows the IEDs to be taken into operation faster than ever before.
- Free protection and control IED manager tool for parameter setting and configuration of the IED.
- Extended HMI functionality with 15 dynamic three-color-indication LEDs, and configurable push-button shortcuts for different actions.
- Programmable LED text-based labels.
- Settable 1A/5A-rated current inputs.

Features

- Fully IEC 61850 compliant
- Protection and monitoring integrated in one IED
- Extensive self-supervision including analog channels
- Four independent parameter setting groups
- Large HMI for visualization of single line diagrams and on-line measurements
- Integrated or detachable HMI with 1-5 m cable for flexible panel mounting
- Ethernet interface for fast and easy communication with PC
- Accurate time synchronization via SNTP, DNP 3.0, IEC 60870-5-103 and IRIG-B serial interface
- Signal matrix for easy configuration of binary and analog signals
- User management and authority handling
- Activity logging

Control functions

- Apparatus control for up to 30 apparatus
- Synchrocheck, energizing check and synchronizing
- Selectable operator place allocation
- Versatile switch with two positions
- Selector switch with up to 32 position

Monitoring

- Disturbance recorder
 - Up to 3 seconds of data before the trigger
 - 100 disturbances
 - 40 analog channels (30 physical and 10 derived)
 - 96 binary channels
- Event list for 1000 events
- Disturbance report
- Event and trip value recorders
- Event counters
- Supervision of AC input quantities
- Indication of up to 135 binary signals via 15 three-color-state indication LEDs
- Insulation gas monitoring function
- Insulation liquid monitoring function
- Circuit breaker condition monitoring
- Station battery supervision

Communication

- IEC 61850-8-1 including GOOSE messaging
- DNP 3.0 slave protocol
- IEC 60870-5-103 serial communication
- 62439-3 standardized Parallel Redundancy Protocol (PRP)

Setting, configuration and disturbance handling

- Protection and control IED manager PCM600

Hardware

- 1/1 x 19" width, 3U height case
- 20 analog inputs (10+1 CT and 9 VT inputs)
- Universal 1A/5A CT inputs
- Communication and processor module with 12 binary inputs, TCP/IP optical, galvanic RS485, and optical serial communication ports
- Binary input/output modules with 9 inputs and 9 outputs
- Possibility to add one optional binary input/output module
- Power supply modules from 24 to 30 V DC, 48 to 250 V DC or 100 to 240 V AC with 9 outputs, 3 of which with trip circuit supervision

COMBIFLEX® and COMBITEST

Proven and reliable solutions for protection and testing



The proven COMBIFLEX® relay family and modular building system offer flexible and reliable protection solutions for a range of applications. You can also combine COMBIFLEX auxiliary relays with Relion® protection and control family products, or other protection relays, to add functionalities such as lock-out, lock-out reset or external contact reinforcement. Using the COMBITEST test system together with, for instance, the Relion family IEDs, provides a safe, secure and easy-to-use method of secondary injection testing of a protection system when performing commissioning and maintenance.

Reliable

The COMBIFLEX relays are in service world-wide since 1960s. The wellknown and proven design provides high reliability and a minimum of maintenance resulting in low cost of operation. All relays are tested according to the highest IEC standards which means that you can integrate them in any protection and control system.

Flexible and safe

The COMBIFLEX building system features unique flexibility for designing various protection schemes. The wide range of different mounting and casing alternatives allows the COMBIFLEX-based protection system to adjust to any space and functionality requirements.

The COMBIFLEX mounting system has been shaped from decades of practical experience of the assembly of complete relay and control systems. The system is based on the 19-inch rack standard which permits a simple combination of products using the same international standard. Every part of COMBIFLEX integrates perfectly forming well-functioning panel designs. The combination of Relion IEDs and COMBIFLEX relays allows you to utilize the space in a cubicle in an optimum way.

The connections in the COMBIFLEX building system, for instance between the relays and test switches, are easy and fast to make using pre-crimped wires – no tools are needed. Additionally, all the connection points in the COMBIFLEX building system are insulated from human contact, which prevents human injuries during installation.



Auxiliary relays for every need

The COMBIFLEX family provides a wide range of auxiliary relays for performing tripping, blocking, interlocking and signaling tasks. They are available with various ratings and contact configurations. The relays, which have a long mechanical life, feature up to 15 contacts. The contacts are suitable for heavy, medium or light duty operation.

The COMBIFLEX auxiliary relays are especially suitable in protection and control circuits, including in highly corrosive atmospheres or seismic areas. This allows you to easily design tripping, interlocking and multiplying functions and logic using a single relay or combinations of relays.

Increase personnel safety with COMBITEST

The COMBITEST relay test system provides a wide range of testing capabilities. Using secondary injection tests allows you to inject signals to an isolated protection device to test its performance and operation limits. This helps you ensure that the protection device operates according to your specifications before an actual protection operation is called for.

The COMBITEST test system allows you to perform secondary injection testing of any protection and control IED and protection relay without disconnecting secondary instrument transformers, for instance CTs, from the protection devices. No external shorting links are needed on the test handle.

When the test-plug handle is inserted into the test switch, the preparations, such as blocking of tripping circuits, short-circuiting of CTs, and opening of voltage circuits, are automatically carried out in the correct sequence. This eliminates the risk of accidental opening of the CT secondary, and tripping a circuit breaker during testing. This makes the secondary injection testing of the protection devices safe for both personnel and equipment.

When the test-plug handle is withdrawn after testing has been completed, the protection device automatically returns to its reset position before the connection to trip circuits is restored.

The COMBITEST test system contains all components required in secondary injection testing. The RTXP test switch and RTXH test-plug handle are available in various sizes, which makes it easy to adjust the test system to your specific needs.

COMBIFLEX[®] and COMBITEST

Product portfolio overview

Relay type	Functionality	Relay	Typical Applications
Auxiliary	General purpose relay	RXMA	Contact multiplication Interposing relays in control equipment Output relays in protection relay AC-supply monitoring
		RXMM	Contact multiplication
	High speed relay	RXMC	Contact multiplication Interposing relays in control equipment Output relays in protection relay
		RXMB	Contact multiplication of primary equipment (eg: Isolator, earth switch)
		RXMS	Tripping in combination with RXME 1//RXMH 2
		RXME	Tripping (low number of contacts)
	Heavy duty bridge contact relay	RXMH	Tripping (high number of contacts)
		RXMT	Ultra high speed tripping Low current applications
	Bi-stable relay	RXMD	Trip lock-out VT Selection
	Bi-stable with heavy duty contacts	RXMVB	Tripping CT-Switching Lock-out
Supervision and Signalling	Supervision relay	RXEM	Trip circuit supervision
	Signal flag relay	RXSF	Transformer trouble indications Signalling application
Time	Time range 0.1 - 320 s	RXKA	Pick-up or drop-out delay Continuous or pulse output LED indication
		RXKL	Pick-up delay Continuous, one-shot or flashing function
	Time range 30 ms - 99 h	RXKM	Pick-up or drop-out delay Continuous and summation time measuring LED indication
Measuring	Fuse supervisory relay	RXBA	Single-, two- or three-phase fuse failures Alarm and block protection equipment
		RXETB	Single- or two-phase fuse failures Alarm only
	Time overvoltage relay	RXEDA	Overvoltage protection Neutral point voltage protection Undervoltage protection DC Voltage protection

COMBIFLEX® and COMBITEST

Product portfolio overview

COMBITEST

Functionality	Product	Additional information
Test-plug handles	RTXH 8 RTXH 18 RTXH 24	Available in three sizes
Test switches	RTXP 8 RTXP 18 RTXP 24	Available in three sizes
Trip block-plug	RTXB	Isolating a trip circuit Monitoring of trip output Visual indication of isolated trip circuit
Ammeter test-plug	RTXM	With local automatic shorting device
Block-plug handle	RTXF	Disconnecting all circuits routes through test switch

Typical Accessories

Product	Description
RHGP	For mounting of single COMBIFLEX relays or/and COMBITEST in a panel cut out With or without front cover with window
RHGX	For flush and semiflush mounting of COMBIFLEX relays or/and COMBITEST Available in 5 sizes
RHGS	For cubicle mounting or surface mounting of COMBIFLEX relays or/and COMBITEST
RXZ	Adapter for DIN-rail or direct surface mounting

Technology summary

COMBIFLEX building system

- Based on the 19-inch rack standard
- Space-saving and rugged construction
- COMBIFLEX plug-in relay modules and terminal basis in four sizes
- Rail, wall, rack, flush and semiflush mounting
- Wide selection of mounting details for different needs, including several casing alternatives (RHGP, RHGS, RHGX)
- Pre-crimped wires (10A and 20A)
- Ready-to-use protection assemblies for different functions and applications, including power supply and tripping relays
- A large amount of accessories to facilitate connection and disconnection of COMBIFLEX relays, for example between relay cubicles or apparatus groups

COMBIFLEX auxiliary relays

- Wide range of auxiliary relays with various ratings and contact configurations
 - General purpose relays
 - High speed and high speed tripping relays
 - Relays with heavy duty bridge contacts with an optional indication flag
 - Relays with single dry-reed contacts
 - Bistable relays and bistable relays with heavy duty contacts
- Operate time down to 1.5 ms
- Low power consumption
- High resistance to shock and vibration
- Up to 15 contacts in one relay

COMBIFLEX supervision and signalling relays

- Signalling relays are available with flags or LEDs
- Supervision relays
- Signal flag relays

COMBIFLEX time relays

- Timing range 30 ms – 99 hours using digital settings
- Rated voltage AC 24-240 V and DC 24-250 V in one relay
- Delay on pick-up, drop-out, continuous or pulsed output

COMBITEST

- Designed to simplify routine tests and commissioning work
- Fail-safe sequence-controlled secondary injection tests
- No risk for accidental trip of the circuit breaker
- Complete isolation of the secondary circuits of the measuring transformers
- Test-plug handles and test switches available in three sizes
 - RTXH 8, RTXH 18, RTXH 24 test-plug handles
 - RTXP 8, RTXP 18, RTXP 24 test switches
- Trip block-plug (RTXB) for isolating a trip circuit without interrupting other circuits, monitoring of the trip output and visual indication of an isolated trip circuit
- Ammeter test-plug (RTXM) with local automatic shorting device in case of inadvertent opening of a CT circuit, for instance due to opening of leads connected to an ammeter
- Block-plug handle (RTXF) for disconnecting all circuits routed through the test switch

Protection and Control IED Manager PCM600

PCM600 provides versatile functionalities for the entire life cycle of Relion® protection and control IED applications. This easy-to-handle tool helps you manage your protection and control equipment all the way from application and communication configuration to disturbance handling, including automatic disturbance reporting.

PCM600 interacts with IEDs over the fast and reliable TCP/IP protocol via a corporate LAN or WAN, or alternatively directly through the communication port at the front of the IED. It is able to read and write all configuration and setting data of an IED with a single command. The user interface, workflow and the IEC 61850-based data model in the PCM600 are designed according to the same philosophy as the Relion protection and control IEDs, ensuring smooth and seamless integration between the tool and the IEDs.

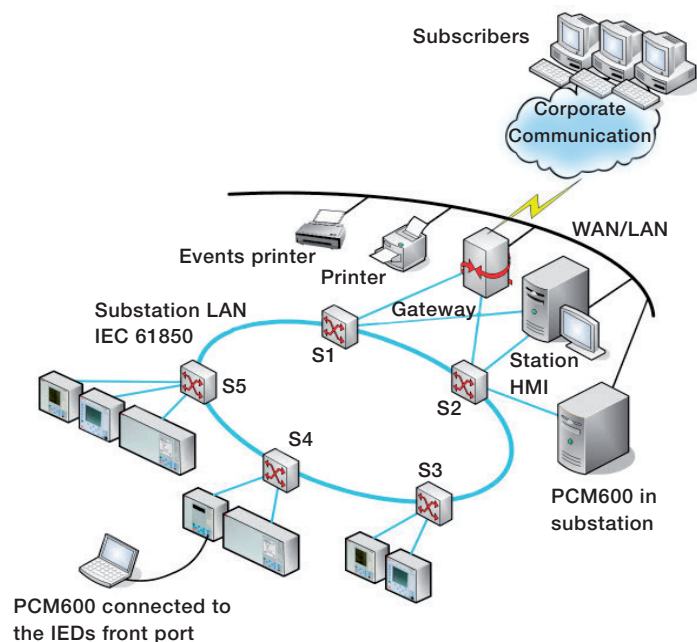

Top 10 features of the Protection and Control IED Manager PCM600

- Powerful application configuration for creation and monitoring of application configuration.
- Graphical representation of parameters simplifies setting of protection function parameters.
- Configuration of IED hardware and IED display.
- Communication management.
- Signal matrix for efficient and flexible connection of CTs, VTs and binary input and output signals, as well as connection of the GOOSE (Generic Object Oriented System-Wide Events) signals between IEDs.
- Comparison of configuration between IEDs and PCM600, and as well as SCL (substation configuration description language) files at SCD (substation configuration description) import.
- Monitoring of IED signals and events.
- Integrated disturbance recording functionalities for scanning and analysis of disturbance information.
- Copy/paste and export/import functions to allow efficient reuse of existing IEDs, bays or substations.
- Utilizes ABB's unique Connectivity Package concept which contains a comprehensive description of the IED, consisting of data signals and parameters as well as the IED documentation.

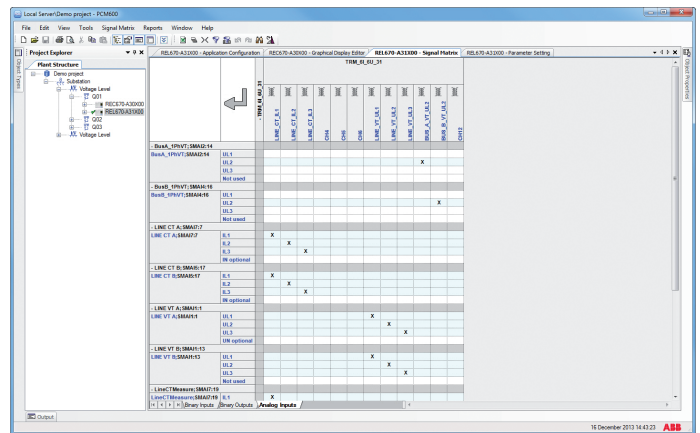
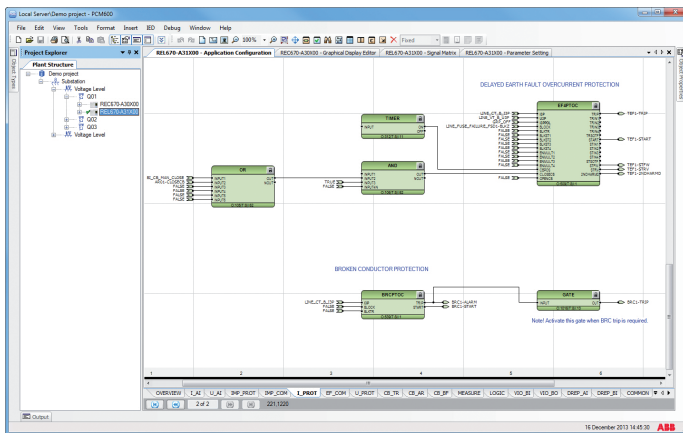

Application configuration allows you to easily create, change or view an IED configuration. Additionally, you can compare the configuration in the tool to the one in the IED. Further, the on-line monitoring functionality helps you to verify the real-time processes in the IED.

With the signal matrix, you can connect the process termination with any I/O connection point in the configuration in the same way as the traditional trip matrix.

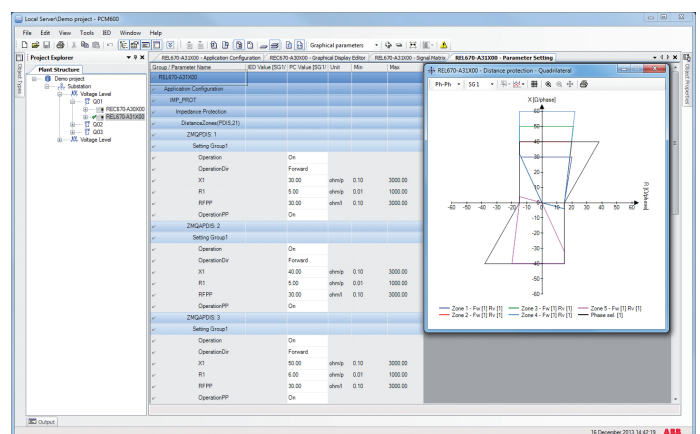
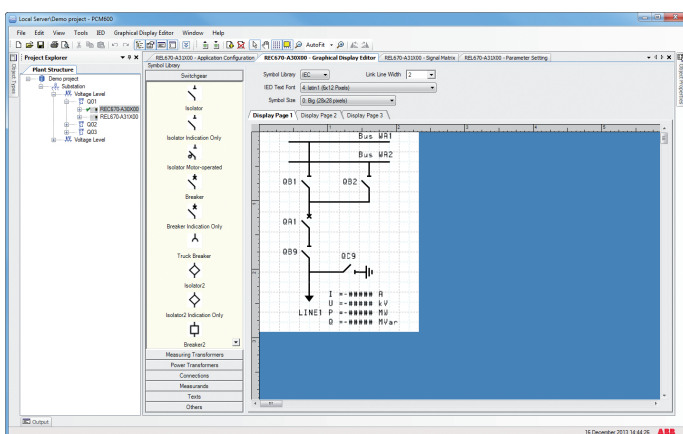

With the graphical display editor, you can easily engineer the single line diagram according to the switchgear arrangement for the IED HMI.

The parameter setting tool allows you to change or view all the parameters that an IED has, for all the setting groups. When reading the parameters from the IED, you can easily compare the values in the PC with the ones in the IED. The graphical representation of protection characteristics supports you in visualizing, for example, distance protection parameter setting.

Integrated Engineering Tool

IET600

Integrated Engineering Tool IET600 is designed for configuring IEC 61850-based substation automation systems and applications. IET600 allows system engineers and integrators to define and configure the complete substation automation system according to IEC 61850. It features powerful graphical interfaces to design the substation topology, manage the communication between all IEC 61850-compliant IEDs in the substation and generate a complete description of the substation in an SCD file.

IET600 provides a simplified, consistent and flexible approach to SA system engineering enabling substation engineers to design the complete system engineering of an IEC 61850-based substation with a single tool.

IET600's combination of powerful engineering editors and built-in IEC 61850 intelligence allows engineers to easily and effectively integrate multi-vendor protection and control IEDs into a SA system. IET600 performs consistency checks at every step of the engineering process, which can significantly reduce the amount of errors not only during system engineering, but also subsequently during the system integration, testing and commissioning phase.

Centralized configuration and maintenance of substation signals for ABB's MicroSCADA platform ensures that data consistency is assured throughout the lifecycle of the substation. The modern and intuitive user interface allows engineers to easily navigate through large amounts of data to find exactly what they need.

With over a thousand deployed systems worldwide, IET600 reflects ABB's long-term IEC 61850 expertise. ABB's UCA International certified in-house System Verification Center continuously ensures that IET600 meets the challenging system performance and integration requirements of any system integrator.

Top 10 features of the Integrated Engineering Tool IET600

- Design and specification of the substation topology in a graphical Single Line Diagram editor.
- Consistent configuration of the complete dataflow communication between all IEC 61850 IEDs in the substation.
- Definition of complete substation configuration in an SCD file according to IEC 61850, including substation topology and communication structure and dataflow.
- Configuration of a wide range of IEC 61850 communication services, including MMS, GOOSE and sampled values.
- Flexible configuration of communication networks to adapt to various substation layouts and system size.
- Import, utilize and create SCL conform files for usage with any IEC 61850-compliant devices and tools in the market.
- Management and comparison functions for SCL-based files allow engineers to manage changes and ensure consistency during project execution.
- Export project data and graphics in Excel and PDF for documentation.
- Centralized management of station and gateway-level signals that ensures data consistency throughout the substation.
- Reuse of previously engineered station and gateway-level signals between multiple IET600 projects.

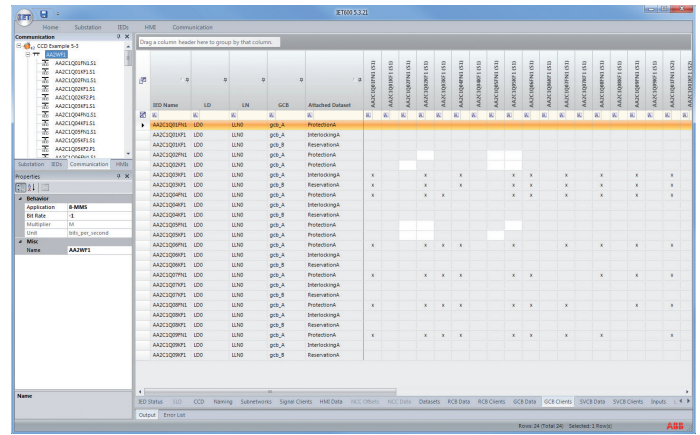
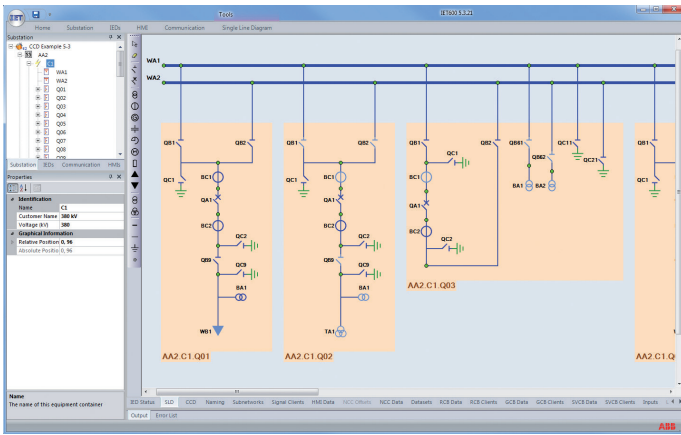

IET600 provides powerful graphic editors to design and configure the substation topology according to IEC 61850. System engineers can easily define the substation layout using the built-in Single Line palette of primary equipment, assign internal and customer-specific names to the devices, and print the configuration for documentation.

IET600's communication editors allow fast and easy configuration of the dataflow between all IEC 61850-compliant IEDs in the substation. Built-in consistency checks and clear representation of information reduces errors during the engineering process.

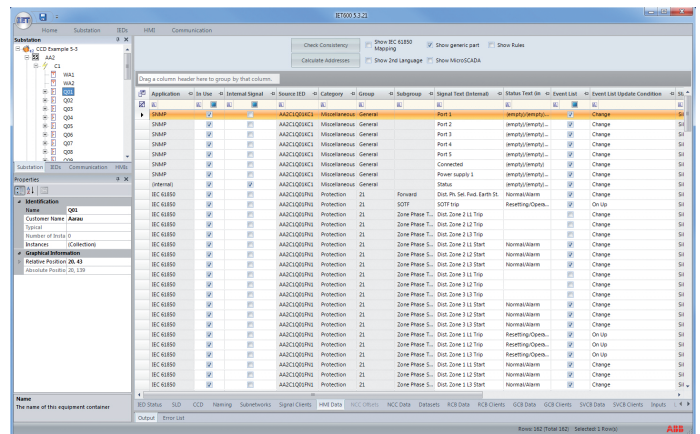
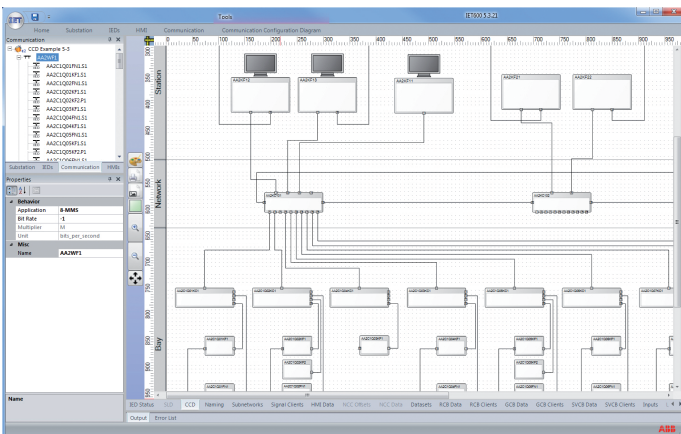

IET600 provides a comprehensive graphical editor for the physical network configuration of the SA System. The detailed layout is included in the exported SCD file and can subsequently be reused for IEC61850 testing and commissioning applications like the ABB ITT600 SA Explorer.

Configure and manage station and gateway-level signals for ABB's MicroSCADA SYS600 platform from IET600 to ensure data consistency throughout the station. Automatic calculations and easy reuse of engineered signals give engineers a powerful means to configure the station computers.

Tool suite for engineering, integration and testing

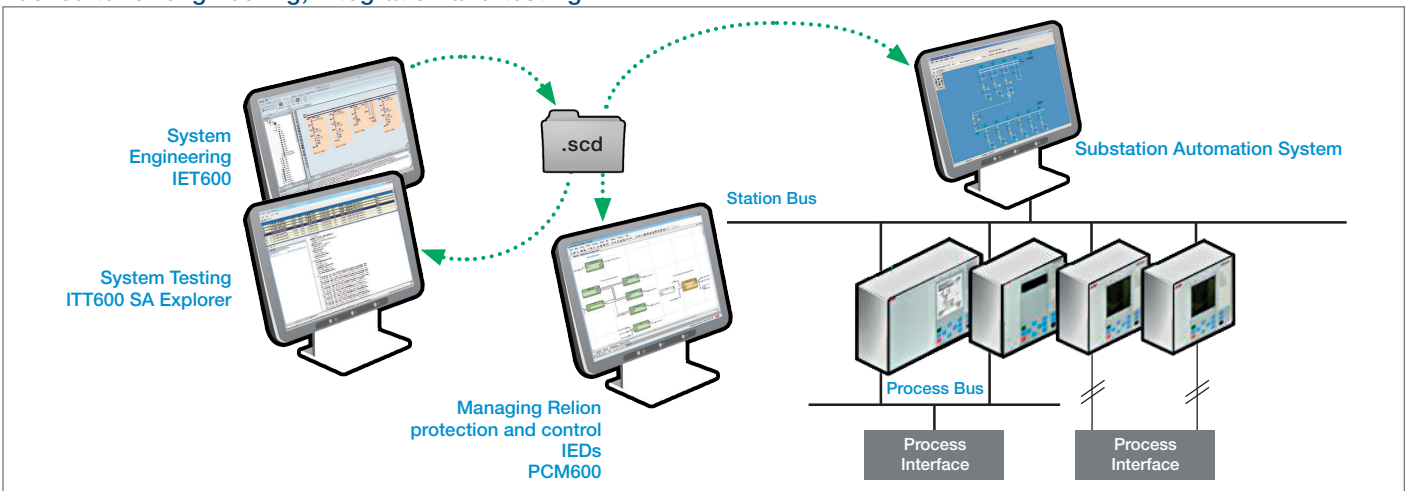

ABB's comprehensive suite of tools for engineering, integration and testing supports you throughout the complete life cycle of protection and control IEDs and IEC 61850-based substation automation systems. With many advanced features, the tools allow you to manage your installation efficiently in all situations from engineering and commissioning to operation and maintenance.

Integrated Testing Tool ITT600 SA Explorer

Integrated Testing Tool ITT600 SA Explorer is designed for easy diagnosis and troubleshooting of IEC 61850-based substation automation systems and applications. It features convenient navigation, comprehensive presentation of application data, and support for system consistency check both on-line and off-line. This allows anybody to use the same tool to analyze and debug substation automation applications regardless of their level of knowledge of IEC 61850 communication.

The ITT600 SA Explorer tool offers facilities for exploring and analyzing the communication configuration of the protection and control IEDs (Intelligent Electronic Devices) and IEC 61850 communication in substation automation systems, including GOOSE messages. Its versatile functionality eliminates the need for multiple testing tools for different purposes, such as MMS browsers, and protocol and Ethernet analyzers.

The powerful features of ITT600 SA Explorer provide test engineers with access to any IEC 61850-compliant IED. The tool's various functions allow efficient testing of the IED application and isolate the root cause of system communication problems. This significantly reduces testing and commissioning time.

ITT600 SA Explorer is easy to use, and does not require the skills of a data communication specialist. By translating the complex terminology of communication protocols into the standardized IEC 61850 language, it makes the essential information available to all users.

Top 10 features of the Integrated Testing Tool ITT600 SA Explorer

- Exploration of the complete IEC 61850 communication configuration of ABB's Relion[®] protection and control IEDs and third-party IEDs.
- Process event list with filtering and exporting capabilities to support testing and commissioning of the IEDs.
- Simulation of an IED based on the loaded data model for both MMS and GOOSE communication.
- Manual and automatic comparison of the system configuration description (.scd) and the deployed IED configurations to ensure data consistency.
- Documentation of the system configuration revisions and IED firmware versions to keep track of the changes in the system.
- Unique graphical visualization of the data flow within an IEC 61850-based system to verify and, if needed, optimize the data flow.
- Visualization of GOOSE data in an Oscilloscope style view simultaneously for several IEDs showing correlations and time measuring. This enables faster debugging and troubleshooting.
- Support for decoding and analysis of substation automation-related Ethernet-based communication protocols, such as IEC 61850-8-1, IEC 61850-9-2, IEC 60870-5-104, DNP 3.0/TCP and Modbus/TCP.
- Comparison of any two SCL-based (substation configuration description language) files at the same time; for instance, comparison of two .scd files to identify the differences between them.
- Visualization of IEC 61850-9-2 LE sampled value streams in a phasor and Oscilloscope style view.

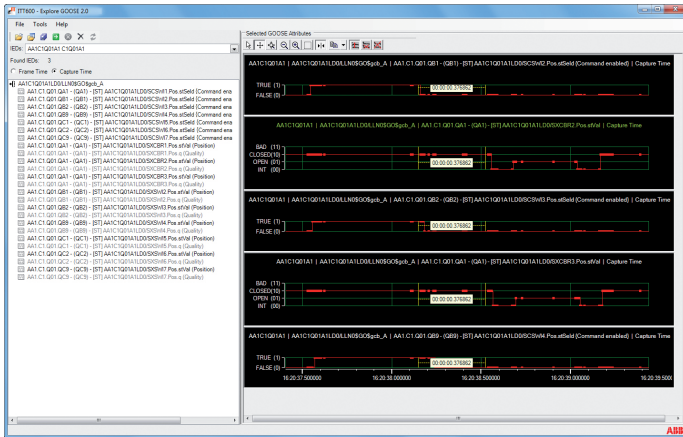

ITT600 SA Explorer makes GOOSE messages visible, and presents the transmitted GOOSE values both on-line and off-line. The tool allows you to focus on the application behavior and verify the traffic instead of searching for specific values in GOOSE frames.

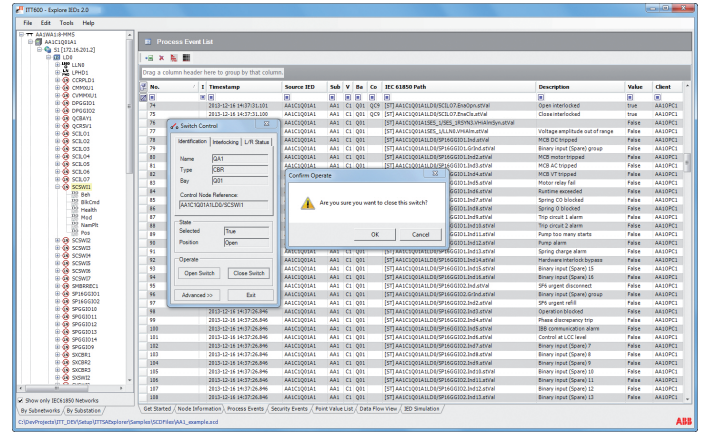

ITT600 SA Explorer allows you to connect to any IEC 61850-compliant IED, browse the IED configuration, subscribe to IEC 61850 reports, send Select-before-operate commands and review the IED's response in the built-in event list.

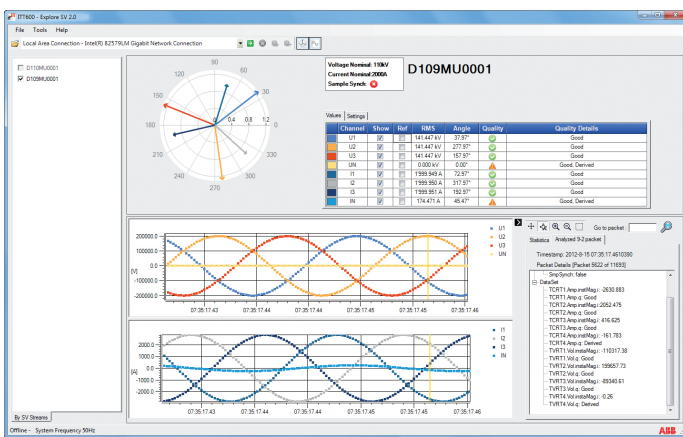

ITT600 SA Explorer visualizes up to two IEC 61850 9-2 LE streams in a phasor diagram and as RMS values to allow engineers to evaluate primary currents and voltages sent by a merging unit on-line. Off-line analysis for one stream includes an Oscilloscope style view of the sampled values.

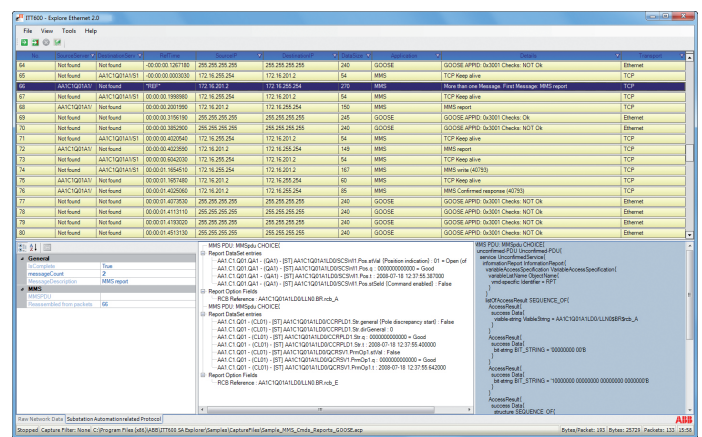

When analyzing communication within a substation automation system, ITT600 SA Explorer allows you to focus on the transmitted payload instead of protocol details. You only need to concentrate on the application values important to you while the tool's unique built-in consistency check functionality takes care of the details.

Services

Power Systems Studies

Every new load, upgrade, extension, and reconfiguration of your network can create unexpected stresses and interactions that the original power system was not designed for. Power system studies provide information that allows you to understand the root of present or future power system problems and to make correct decisions in planning upgrades or extensions in your power system, which lead to reduced operating costs, increased availability and minimized equipment or system failure.

Our Power System Studies are always tailored to your needs. They are aimed at analyzing the operation of your power system during normal conditions and in fault situations by using one or several of the studies mentioned above. In this way our power system studies enable you to take the correct actions in optimizing the design, function and operation of your protection and control system.

Power System Simulation

Power system simulations provide valuable information about disturbances and their effects on your power system - even before they occur. And, when you know about them, you can minimize the effects or even prevent disturbances from happening! Thus, ABB's power system simulations allow you to profit from a correct protection and control strategy, and secure power system operations.

By means of the digital real-time network simulator, ABB experts are able to simulate transients in your power system, and analyze and verify the operation of your protection and control equipment under various conditions. Combined with our Power System Studies, simulation systems can be fully adapted to represent the characteristics of your network.

Parameter Setting and Configuration

The configuration and parameter setting services help you gain the best advantage from your investment by allowing you to create the optimum system protection scheme and selectively isolate faults to minimize system outage times.

These services ensure that the functionality of the terminals meets the requirements of your network, and that the equipment operates correctly in all predictable fault situations.

We adapt configuration and parameter settings of protection and control equipment to your fault clearance requirements. This is done based on short-circuit and protection coordination studies, also called selectivity planning.

Disturbance Analysis

Faults provide a good opportunity to analyze the power system and its behavior in fault situations, as well as the performance of the protection and control system. Thorough analyses and comprehensive reports including facts and



conclusions about the disturbance can be used to identify the root causes behind the fault. Based on the results, our experienced specialists will suggest corrective actions which help you focus on the relevant parts of the power system, thus allowing you to optimize your power system operation.

Product Upgrading

Product upgrading service offers you an easy and cost-effective way to increase the functionality of your protection and control equipment to keep up with the changes in your power system and to benefit from the latest developments of our protection and control IEDs. It allows you to increase the functionality of power system protection and control without installing new hardware equipment. This, in turn, minimizes installation and wiring costs, since installation in the existing cubicles can be done with no or limited changes in wiring.

Depending on your choice, the upgrading can be done on your site or at our factory. Furthermore, upgrading of IEDs protects your initial investment as future needs and development can be addressed by simply adding new protection and control functions.

Commissioning

Commissioning work plays an essential role in ensuring that the equipment is correctly assembled and connected, has proper ratings and is correctly configured and set so that the overall system will perform correctly.

Training

We offer standard training courses pre-scheduled for each semester. Customized courses will be offered on request. Customized training classes will meet your specific requirements for our products either at your location or at our facilities.

Our training courses provide engineers and operators a unique opportunity to benefit from ABB's deep power system knowledge.

In our training courses you will meet experienced and dedicated instructors. You will also be able to share experiences with other participants. In addition to lectures, our training courses include extensive hands-on sessions and well-documented exercises. This will help you to be well prepared to efficiently handle your equipment.



Standard or customized training

We offer standard training courses pre-scheduled for each semester. Customized courses will be offered on request.

Customized training classes will meet your specific requirements for our products either at your location or at our facilities. Please consult the training administration for further information.

Repair

Our repair and fault-finding process starts with visual inspection, detailed inspection and diagnostic measurements, continuing with the actual repair work, and ending with functional tests and report writing. This service ensures that the parts meet their original specifications after repair.

Root Cause Analysis

In cases where an IED has failed, it may be of interest to identify the reason for its failure. Our Root Cause Analysis Service is an in-depth analysis of the defective software and hardware to possibly identify irregularities and provide solutions.

Excellence in real time power system simulation

ABB has a long and well-documented history of real time power system simulations for the verification of protection, control and monitoring products. You can obtain a quick check on how the protective system in your power network will behave when disturbances occur in the system. By connection the protection IEDs to the Real Time Digital Power system Simulator (RTDS), network can be simulated to suit your own specifications. Moreover, you can take the necessary measures, at the least possible investment cost to eliminate the risk of serious power failure.

A modern protection device must make decision, within a few milliseconds, on disconnection of a faulted grid element and the stability of a power system depends on correct functioning of them. On the other hand, unnecessary disconnection may lead to more serious breakdowns in power distribution than can be tolerated.

By testing your protection system in our simulator, you can quickly predict how the protection devices will behave under various disturbances. This knowledge is invaluable in building up a stable and reliable power network.

Increased complexity calls for verification

With the increasing complexity of power system and the diversity of new protection, control and monitoring products,

demands for power systems simulations is increasing. Some of the factors that call for customer specific simulation and verification are:

- Network topology, such as parallel and multi terminal line
- Increasing diversity of components in power network, such as HVDC line and FACTS devices.
- High speed protection
- Multi terminal protection
- Long lines with load encroachment
- Introduction of new numerical techniques in protections, such as adaptive algorithms and fuzzy logic.

A copy of your own power network

Power system simulation services will help you to study possible disturbance and know their effects on your power system. ABB SA Product department, provider of protection IEDs, offers simulation tests with the following possibilities:

- Faults analysis in different locations in the power system
- Breaker operations as opening, closing and re-closing
- Short term network stability variation
- Power swing analysis
- Different load conditions

Additionally, the advanced simulator for substation equipment, such as for on-load tap changer and power transformers, can be used for verifying control devices designed, for instance, for voltage control.



Feature of the ABB simulator (RTDS)

Technical details

The ABB real time power system simulator offers the advanced and effective means for verifying protection and control equipment for specific applications. Since the simulation runs in real time the physical protection equipment can be connected in closed-loop with the power system model.

In the open-loop testing, calculated voltages and currents or playback of COMTRADE files from simulator can be used. Moreover, the closed-loop interaction of the protection system with the network model provides insight on both the performance of the IED scheme as well as its effect on the power system.

The flexibility in topology, model and automatic test sequences allows protection equipment to be subjected to virtually all possible faults and operating conditions.

Model data base

A model of the power system is implemented on the RTDS Simulator that includes the high voltage components (e.g. lines, breakers, instrument transformers, power transformers, generators, etc) plus the required protection and control functions not included in the equipment under test. Moreover, typically detailed models of the instrument transformers (CT, PT and CVT), makes it possible to evaluate their effect on the performance of the protection system.

Real time connection

The simulator communicates to tested protection, control and monitoring equipment via optical fibers, I/O-equipment and amplifiers. The interface with simulator consists of:

- 12 powerful current amplifiers (160 A at 100 V peak)
- 12 powerful voltage amplifiers (260 V at 1 A peak)
- 256 logical signals from IEDs indicate breaker position, blocking or permissive signals, etc.

Presentation of test results

Tests and verifications performed at the ABB real time simulation center are fully and clearly documented.

The case documentation includes:

- Input data files (network configuration, parameters etc.)
- Load flow data
- Result data files with current, voltages and logical signals
- Printed result tables and graphs

Notes

.....
.....
.....
.....
.....
.....
.....
.....
.....
.....
.....
.....
.....
.....
.....
.....
.....
.....
.....
.....
.....
.....
.....
.....
.....
.....
.....
.....
.....
.....
.....
.....
.....
.....
.....
.....
.....
.....
.....
.....
.....
.....
.....
.....
.....
.....
.....
.....
.....
.....
.....
.....
.....
.....
.....
.....
.....
.....

Contact us

For more information please contact:

ABB AB

Substation Automation Products

721 59 Västerås, Sweden

Phone: +46 (0) 21 32 50 00

www.abb.com/protection-control

Note:

We reserve the right to make technical changes or modify the contents of this document without prior notice. ABB AB does not accept any responsibility whatsoever for potential errors or possible lack of information in this document.

We reserve all rights in this document and in the subject matter and illustrations contained herein. Any reproduction, disclosure to third parties or utilization of its contents – in whole or in part – is forbidden without prior written consent of ABB AB.

© Copyright 2014 ABB.

All rights reserved.

1MRK500099-SEN 10/2014



Scan this QR code to visit our website